

# Biometric Automobile Ignition Locking System

Guguloth Thukaram

PG Student , Department of Electronics & Communication Engineering, GokarajuRangaraju Institute of Engineering & Technology, Hyderabad, Telangana State, India.

**Abstract**-Automobile theft is the biggest problem in the remote location of the city and neither key lock nor Remote keyless system provides reliable solution because key can be copied very easily and remote keyless system encrypted data use radio waves which can be recorded and used to unlock the car. To design a unique key which doesn't rely on key or radio wave, biometric solution is the only better option. Our purpose here is to provide biometric solution with very low cost hardware and using open source hardware and software tool plus does it your self-installation.

**Index Terms**- Automobile theft security, automobile ignition control, open source hardware and software, do it your self-installation.

## 1. INTRODUCTION

Every person has its own unique fingerprint which can be used as unique unlock/lock key of your automobile. This can solve the problem of key theft where your automobile can only be started when it detects unique fingerprint assign to it. Thus the control of the ignition coil and accessories connection of automobile is required.

There are many devices available to protect your automobile to prevent the theft but many of the solutions are available to few international brands and the installation is costly when it comes to third party. Using an open source hardware and software with some knowledge of your automobile allows us to design our own little but reliable security system.

## 2. MARKET SURVEY ON ANTI-THEFT DEVICES

There are many devices available in the market to give you good antitheft solution. Some of easy install and cheap solution is mechanical immobilizers [1] like steering wheel lock, hood lock, tire lock, gear shift lock, ignition/steering wheel column lock and

brake pedal lock. There is electronic version of immobilizers available which can lock the ignition system or fuel system until special key combination (using some keypad) or combination of various pedals are entered.

Mechanical immobilizers are cheap but not so good solution when car key is stolen. while good electronic immobilizers are available with higher price with extra installation and maintenance charge.

The article provided by Delhi police does not give you effective guidance on antitheft [2], thus it is necessary to design a device that lock our automobile with unique key, a biometric locking system.

## 3. SURVEY ON AUTOMOBILE THEFT

There is a good article written by Indian express [3] about automobile theft in metro city like Delhi. In Delhi 2 case is registered in every 30 minutes. Software-Savvy, Tech-Friendly Thieves Armed with latest technology and tools, come in group of four or five, expert in every field on automobile engineering, they can find a way in [4]. They don't require to copy the ignition key as they use some Chinese software "the Engine Control Module (ECM) code breaker", available online and costs Rs 1 lakh. They can break steering lock and gear box lock with specialized tools and start the car. Here is the case study on automobile theft by Indian express [3]

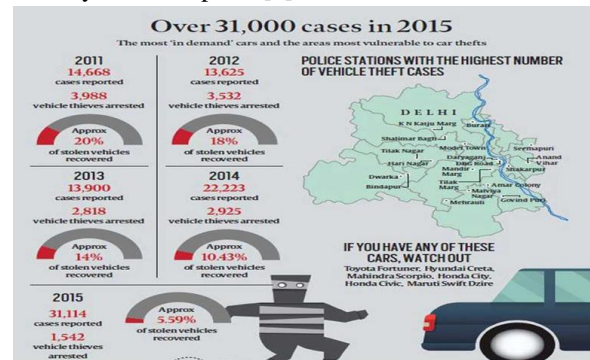

Figure1 Survey of Indian expresses about car theft and solved case

4. OBJECTIVE

To provide cheaper solution, we use open source hardware and software tools. Arduino is an open-source electronics platform based on easy-to-use hardware and software. It's intended for anyone making interactive projects. The plans of the Arduino boards are published under a Creative Commons license, so experienced circuit designers can make their own version of the module, extending it and improving it. The Arduino software is easy-to-use for beginners, yet flexible enough for advanced users. It runs on Mac, Windows, and Linux. The Arduino software is published as open source tools, available for extension by experienced programmers. The language can be expanded through C++ libraries, and people wanting to understand the technical details can make the leap from Arduino to the AVR C programming language on which it's based. Similarly, you can add AVR-C code directly into your Arduino programs if you want to.

5. BLOCK DIAGRAM OF SYSTEM

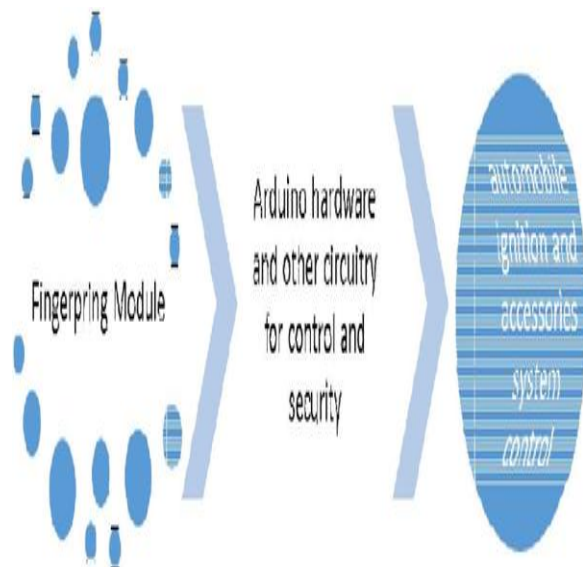

Figure 2 Fingerprint ignition and accessories control block diagram

5.1. Finger Print Module

R305 Fingerprint module is one of the best and cheap sensor. It has TTL serial mode for communication

which makes it easier to interface with any microcontroller based system. It comes around 2200 rupees from robokit India. Detailed version of datasheet is given in reference [5]. Adafruit provide good information on module as well as instruction for interfacing with Arduino [6]. They also provide good library to interface fingerprint module with Arduino, the source code is available on GitHub [7].

6. IGNITION KEY DIAGRAM

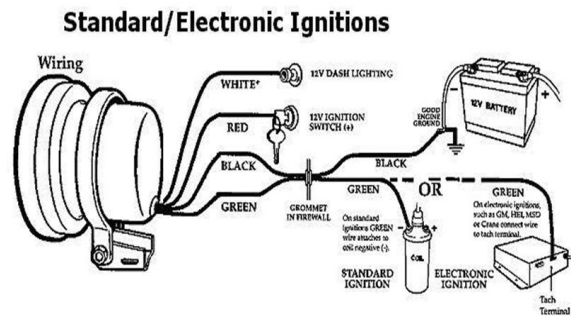

Figure 3 Standard 4-wire electronics ignition system key locking

7. SCHEMATIC OF SYSTEM

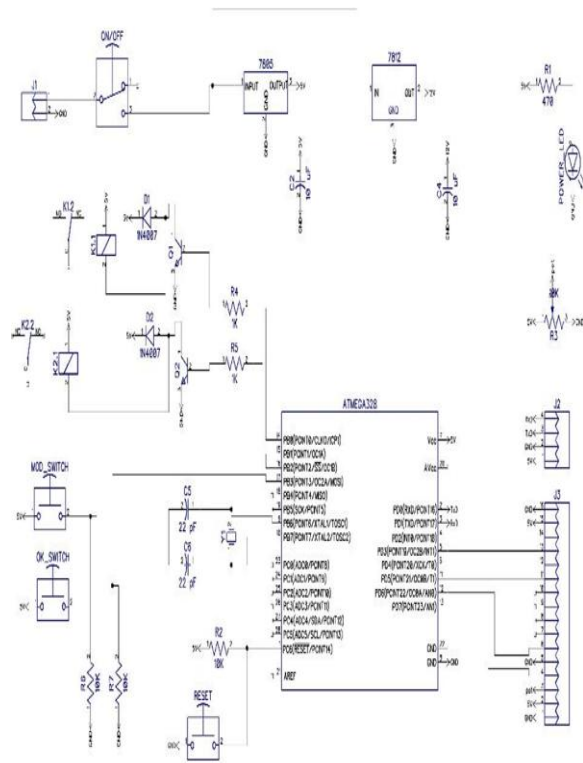

Figure 4 Schematic diagram (designed with diptrace free edition four windows)

### 8. CIRCUIT BOARD LAY OUT

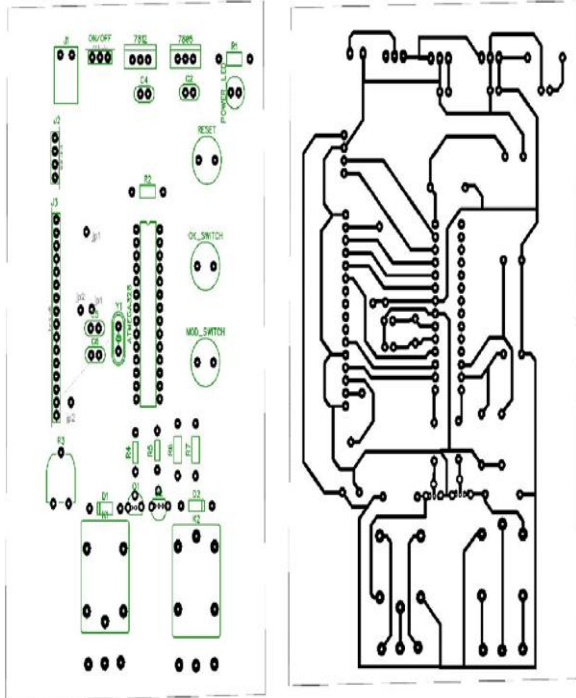

Figure 5 Circuit board layout (top view on left and bottom view on right) (designed with diptrace free edition for windows)

### 9. SOURCE CODE

```
#include <Adafruit_Fingerprint.h> #include
<LiquidCrystal.h>boolean toggle = false;

uint8_t p; char c; uint8_t d; uint8_t id; uint8_t
getFingerprintEnroll(); uint8_t stat=255;

uint8_t getFingerprintIDez(); Adafruit_Fingerprint
finger = Adafruit_Fingerprint(&Serial); uint8_t
readnumber(void); uint8_t deleteFingerprint(uint8_t);
uint8_t

uploadFingerpintTemplate(uint16_t); constint
sw2=11; constint sw1=10; intmode_switch_stat=0;

intok_switch_stat=0; constintBike_start=8;
constintbat_start=9;

constint RS=7; constint EN=6; constint D4=5;
constint D5=4; constint D6=3; constint D7=2;
LiquidCrystallcd(RS, EN, D4, D5, D6, D7); void
setup() {pinMode(sw1,
```

```
INPUT); //mode switch pinMode(sw2, INPUT); //ok
switch pinMode(Bike_start,OUTPUT);
pinMode(bat_start,OUTPUT);
digitalWrite(Bike_start,LOW);
digitalWrite(bat_start,LOW); Serial.begin(57600);
```

```
lcd.begin(16, 2); lcd.setCursor(0, 0);
lcd.print("fingerprint bike"); lcd.setCursor(0, 1);
lcd.print("unlocked system"); delay(1000);
lcd.clear();
lcd.print(" Initializing"); delay(1000);
finger.begin(57600);
```

```
// set the data rate for the sensor serial port
```

```
if (!finger.verifyPassword()) { lcd.clear();
lcd.print("Did not find"); lcd.setCursor(0, 1);
```

```
lcd.print(" sensor :("); while (1); }
```

```
if(finger.loadModel(0)!=FINGERPRI NT_OK)
{lcd.clear();
```

```
lcd.print("No Master Detected"); delay(2000);
lcd.print("Enrolling Master"); lcd.setCursor(0, 1);
lcd.print("Fingerprint");
```

```
id=0;while (!getFingerprintEnroll() ); }} void loop()
{ mode_switch_stat==LOW; ok_switch_stat==LOW;
delay(1000); lcd.clear();
```

```
lcd.print(" Waiting for "); lcd.setCursor(0, 1);
lcd.print(" valid finger ");
```

```
stat=255; stat=getFingerprintIDez(); if(stat==255) {
delay(1000); lcd.clear();
```

```
lcd.print("error!!try again"); } else {
mode_switch_stat=LOW;
```

```
delay(100);mode_switch_stat=digitalRead(sw1);dela
y(100);
```

```
if(stat==0 &&mode_switch_stat==HIGH{ //special
mode open delay(1000)
lcd.setCursor(0, 1);
```

```
lcd.print(" 3.delete"); delay(4000); lcd.clear();
lcd.print("enter choice "); d=readnumber();
```

```
lcd.setCursor(0, 1); lcd.print(" "); lcd.print(d); switch
(d){ case 1: delay(1000); lcd.clear(); lcd.print("Ready
to enroll"); lcd.setCursor(0, 1);
```

```
lcd.print("a fingerprint!");delay(1000); lcd.clear();
lcd.print("Please Type the"); lcd.setCursor(0,
1);lcd.print("ID
```

```
# "); id = readnumber(); delay(1000);
lcd.clear();lcd.print("Enrolling ID # ");
lcd.setCursor(0, 1); lcd.print(id); while (!
getFingerprintEnroll() ); break; case 2: delay(1000);
lcd.clear(); lcd.print("Enter ID # ");
```

```
id = readnumber(); lcd.setCursor(0, 1); lcd.print(id);
delay(1000); uploadFingerpintTemplate(id); break;
case 3: delay(1000); lcd.clear(); lcd.print("Type the
ID you"); lcd.setCursor(0, 1);
```

```
lcd.print("want delete# "); id = readnumber();
lcd.print(id); delay(1000); if(id==0) {
```

```
delay(1000); lcd.clear(); lcd.print("you cannot
delete"); lcd.setCursor(0, 1); lcd.print("Master id"); }
```

```
else{
```

```
delay(1000); lcd.clear(); lcd.print("deleting ID #
");lcd.print(id); deleteFingerprint(id); }break;
```

```
default:
```

```
delay(1000);lcd.clear(); lcd.print("wront entry try
again!"); } } else if(stat!=255) {toggle = !toggle;
digitalWrite(Bike_start,toggle);
digitalWrite(bat_start,toggle); delay(1000);
```

```
lcd.clear(); if(toggle==1) lcd.print(" bike started");
else lcd.print(" bike stopped"); delay(5000); }
```

```
else {
```

```
delay(1000); lcd.clear(); lcd.print("wrong entry try
again!"); } } delay(50);}
```

```
// returns -1 if failed, otherwise returns ID #
```

```
uint8_t getFingerprintIDez() { p=255;
while (p != FINGERPRINT_OK) { p =
finger.getImage();
```

```
p = finger.image2Tz();
```

```
p = finger.fingerFastSearch(); }
```

```
// found a match!
```

```
return finger.fingerID; p=255; } uint8_t
readnumber(void) { mode_switch_stat=LOW;
ok_switch_stat=LOW;
```

```
uint8_t num = 0;
```

```
while (ok_switch_stat==LOW) {
mode_switch_stat=digitalRead(sw1);
ok_switch_stat=digitalRead(sw2); delay(250);
if(mode_switch_stat==HIGH) num++;
while(mode_switch_stat!=LOW
&&ok_switch_stat!=LOW); }
return num;}
```

```
uint8_t getFingerprintEnroll() { int p = -1;
delay(1000); lcd.clear(); lcd.print("Waiting for id #");
lcd.print(id); lcd.setCursor(0, 1); lcd.print("valid
finger ");
```

```
while (p != FINGERPRINT_OK) { p =
finger.getImage(); delay(1000);
```

```
switch (p) {case FINGERPRINT_OK:
lcd.clear();lcd.print("Image taken"); break;
```

```
case FINGERPRINT_NOFINGER:
lcd.print(".");break;
```

```
case FINGERPRINT_PACKETRECEIVEE RR:
```

```
lcd.clear();
```

```
lcd.print("Communication err");break; case
FINGERPRINT_IMAGEFAIL: lcd.clear();
lcd.print("Imaging error"); break; default:
lcd.clear();lcd.print("Unknown error"); break; } //
OK success!
```

```
p = finger.image2Tz(1); delay(1000); switch (p) {
case FINGERPRINT_OK: lcd.clear();
lcd.print("Image converted");break; case
FINGERPRINT_IMAGEMESS: lcd.clear();
lcd.print("Image too messy"); return p;
```

```

case FINGERPRINT_PACKETRECIEVEE RR:
lcd.clear(); lcd.print("Communicationerr");

return p;
case FINGERPRINT_FEATUREFAIL:
lcd.clear();lcd.print("Could not find ");
lcd.setCursor(0, 1); lcd.print("fingerprint features");

return p; case

FINGERPRINT_INVALIDIMAGE:
lcd.clear();lcd.print("Could not find ");
lcd.setCursor(0, 1); lcd.print("fingerprint features");

return p; default: lcd.clear(); lcd.print("Unknown
error"); return p;} delay(1000);lcd.clear();
lcd.print("Remove finger"); delay(1000);p = 0;while
(p != FINGERPRINT_NOFINGER) {

p = finger.getImage();} delay(1000); lcd.clear();
lcd.print("ID "); lcd.print(id); p = -1; delay(1000);
lcd.clear(); lcd.print("Place same "); lcd.setCursor(0,
1);

lcd.print("finger again");

while (p != FINGERPRINT_OK) { p =
finger.getImage(); delay(1000);

switch (p) {case FINGERPRINT_OK: lcd.clear();
lcd.print("Image taken"); break; case
FINGERPRINT_NOFINGER: lcd.print("."); break;

case FINGERPRINT_PACKETRECIEVEE RR:

lcd.clear();

lcd.print("Communication err"); break;
case FINGERPRINT_IMAGEFAIL: lcd.clear();
lcd.print("Imaging error"); break; default: lcd.clear();
lcd.print("Unknown error");break;}}

// OK success!

p = finger.image2Tz(2); delay(1000); lcd.clear();
switch (p) {

case FINGERPRINT_OK: lcd.print("Image
converted"); break; case

```

```

FINGERPRINT_IMAGEMESS: lcd.print("Image too
messy"); return p; case
FINGERPRINT_PACKETRECIEVEE RR:

lcd.print("Communication err"); return p; case
FINGERPRINT_FEATUREFAIL: lcd.print("Could
not find "); lcd.setCursor(0, 1); lcd.print("fingerprint
features"); return p; case
FINGERPRINT_INVALIDIMAGE: lcd.print("Could
not find "); lcd.setCursor(0, 1); lcd.print("fingerprint
features"); return p;

default: lcd.print("Unknown error"); return p; }

// OK converted! delay(1000); lcd.clear();

lcd.print("Creating model for #"); Serial.println(id);

p = finger.createModel(); delay(1000); lcd.clear();if
(p == FINGERPRINT_OK) { lcd.print("Prints
matched!"); } else if (p ==
FINGERPRINT_PACKETRECIEVEE RR)
{lcd.print("Communication err"); return p;} else if (p
== FINGERPRINT_ENROLLMISMATC H)
{lcd.print("Fingerprints "); lcd.setCursor(0, 1);

lcd.print("did not match");return p;} else
{lcd.print("Unknown error"); return p;}delay(1000);
lcd.clear();lcd.print("ID "); lcd.print(id);p =
finger.storeModel(id); delay(1000);lcd.clear();

if (p == FINGERPRINT_OK) {
lcd.print("Stored!");} else if (p ==
FINGERPRINT_PACKETRECIEVEE RR)
{lcd.print("Communication err"); return p;} else if (p
== FINGERPRINT_BADLOCATION) {
lcd.print("Could not find "); lcd.setCursor(0, 1);
lcd.print("fingerprint features"); return p; } else if (p
== FINGERPRINT_FLASHERR) { lcd.print("Error
writing"); lcd.setCursor(0, 1); lcd.print("to flash");
return p; } else {lcd.print("Unknown error");

return p;} } uint8_t deleteFingerprint(uint8_t id)
{uint8_t p = -1; p = finger.deleteModel(id);
delay(1000); lcd.clear();if (p ==
FINGERPRINT_OK) lcd.print("Deleted!"); else {
lcd.print("Unknown error: 0x");
lcd.print(p, HEX); return -1;}}
uint8_t

```

```

uploadFingerprintTemplate(uint16_t id)
{uint8_t p = finger.loadModel(id);
delay(1000); lcd.clear(); switch (p) {
case FINGERPRINT_OK:
lcd.print("fingerprint "); lcd.print(id);
}
lcd.setCursor(0, 1);lcd.print("available");
break;
case
FINGERPRINT_PACKETRECEIVED:
RR: lcd.print("Communication err");
return p;default: lcd.print("fingerprint");
lcd.print(id); lcd.setCursor(0, 1);
lcd.print(" not available");return p;
} // OK success!

```

## 10. FUTURE DEVELOPMENT

We can install GPS with GSM for vehicle tracking and to send alert on repetitive unauthorized unlock request. This helps us to completely lock down automobile and immediate tracking.

We can install remote control automobile controller by which we can control security features like remote ignition locking, remote steering locking, remote gear box locking, remote door locking, or remote alarming system.

## 11. CONCLUSION

We can design our own security system with our own unique hardware, which cannot be crack by thief easily. Car unlocking method is only valid fingerprint which is unique for each user. Designing hardware is very easy because it is based on open source hardware, which provide easy to design hardware solution which remove the hassle of study of internals of controller. Software code is open source having so many API for control purpose which helps to develop our source code with ease. Taking the help of Adafruit library and open source Arduino IDE we can develop source code without hassle of internal architecture of Fingerprint Module.

## REFERENCE

[1] Various anti-theft devices for car protection article by

- wikihow <http://www.wikihow.com/Choose-the-Best-Anti-Theft-Devices-to-Protect-Your-Car>
- [2] Delhi police anti auto theft informatics. <http://www.delhipolice.nic.in/home/auto-theft.htm>
- [3] Article of Indian express about car-theft in metro city like Delhi <http://indianexpress.com/article/delhi/hardlook-c-for-car-thefts-in-capital-and-cops-who-cant-keep-up/>
- [4] Article of Indian express about modern automobile thief.
- [5] <http://indianexpress.com/article/cities/delhi/software-savvy-tech-friendly-thieves-armed-with-latest-technology-and-tools-car-thieves-find-a-way-in/>
- [6] R305 Fingerprint module datasheet. <http://www.rhydolabz.com/documents/fingerprint-module.pdf>
- [7] Adafruit informatics page for fingerprint sensor. <https://learn.adafruit.com/adafruit-optical-fingerprint-sensor>
- [8] Akshatha M.M, Lokesh B and Nuthan A.C , “A Novel Technique of Visual Cryptography for Maintaining the Security of Visual Information Transaction”, International Journal of Electronics and Communication Engineering & Technology (IJECET), 5(8), 2014, pp.194-199.
- [9] Adafruit fingerprint sensor library on GitHub. <https://github.com/adafruit/Adafruit-Fingerprint-Sensor-Library>.
- [10] Mohamed Basheer. K. P and Dr. T. Abdul Razak, “Enhanced Biometric Based Authentication for Network Security using IRIS”. International Journal of Computer Engineering and Technology (IJCET), 4(6), 2014, pp. 412–422.