

Latest Trends in Industrial Uninterruptible Power Supply

ASHISH KUMAR LODHWAL¹, DEEPESH GARG², GAURAV TALWAR³

^{1,2,3} Dept. of Electrical Engineering, Poornima College of Engineering, Jaipur

Abstract -- An uninterruptible power supply, generally called an UPS is a gadget that can change over and control coordinates current (DC) vitality to substituting current (AC) vitality. It utilizes an ordinary battery of 12V rating as the information source and by the activity of the inverter hardware; it delivers a rotating voltage which is sent to the heap. This specific UPS is intended for a little scale stack like a PC and consequently just an essential power rate is produced by the UPS. Standard Uninterruptible Power Supply (UPS) frameworks are associated in arrangement between the air conditioner mains and the basic load. A stage controlled rectifier encourages a battery-upheld dc transport and an inverter supplies the heap. These frameworks require two transformation stages. Info control factor is poor and substantial symphonies streams are infused into the air conditioner mains. The proposed model will recognizes the individual from forthcoming shortcomings and recommend its cure by means of SMS. On the off chance that conceivable apply the cure steps and stay away from the blame.

Indexed terms -- Embedded System, Uninterrupted Power Supply, Personal Computer, Automation, Power Electronics, Load centers, Ultra capacitor storage, Remote device management.

I. INTRODUCTION

The industrial processes expansion become very complex the electronic systems. The costs of not planned stops are so high that a project for fault detection and fault isolation has been very important. The advances in the Information Technologies allow that one people through a mobile phone has instantaneous access to an information in practically any place of the world. This work proposes the development of a system that reduces the time where an UPS system it is remained in the period after-faults until the maintenance. In this period, depending on the fault, part of the components still is in full operation, however, if to keep them thus for a long time will be compromise all system. The developed device analyzes the behaviour of the equipment and detects some types of faults. After that it transmits through one GSM link the detected fault.

Broadly the UPS can be classified as the Static UPS system and Rotary UPS system. The static UPS system uses power electronics converters and inverters to process, store, and deliver power in grid failure, while Rotary UPS uses motors and generators for the same function. Sometime the combination of both static and rotary UPS system is used usually called hybrid UPS System. Wide range of UPS systems is available in the market depending upon their ratings. The smaller units of only 300VA are used to provide back up to single computer, but the bigger unit of UPS may provide backup to entire building of several megawatts.

To cope with the recent issues of global warming and green- house gas emission, the use of renewable energy resources is tremendously increasing. UPS system with photovoltaic power has also been introduced in to utilize the solar energy for longer period of time.

II. CLASSIFICATION OF UPS

Depending on the topological configuration, the UPS system is classified as Offline UPS, Line interactive UPS, and Online UPS system.

2.1) Offline UPS:

The offline UPS consists of a battery charger, a static switch, and an inverter as shown in Fig. 1. A filter and a surge suppressor are sometimes used at the output of the UPS to avoid line noise and disturbance before being supplied at the output of the UPS. During normal mode operation, a battery charger will charge the battery bank, and at the same time the load is being fed by the power from main AC line.

The exchanging time of the static switch is regularly under 10ms, which does not influence the typical PC stack. The benefits of the offline UPS are minimal effort, basic plan, and littler size of the framework. Be that as it may, the absence of genuine confinement

from the heap and the absence of voltage control are the principle downsides of the offline UPS framework. Additionally the execution of this framework amid non-straight load is likewise exceptionally poor. Offline UPS are appropriate for littler burdens with rating of around 600 VA.

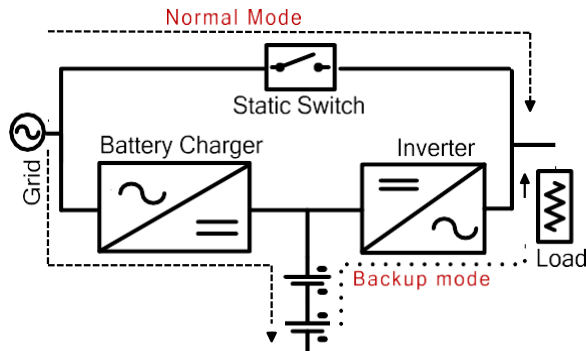

Fig. 1: - Block Diagram of Offline UPS System.

2.2) Line Interactive UPS system:

Line Interactive UPS consists of a static switch, bidirectional converter/inverter, and a battery bank. The bidirectional converter/inverter connects the battery bank to the load. During normal mode of operation, the main AC line supplies the power to the load and the bidirectional converter/inverter charges the battery. During the grid failure, the static switch disconnects the load from the main supply and the bidirectional converter/inverter supplies the power to the load. The line interactive UPS has the advantages of low cost, small size, and high efficiency.

2.3) Online UPS System:

Online UPS consist of a rectifier, an inverter, and a static switch as shown in the fig.2. During normal mode of operation, the rectifier charges the batteries as well as maintains the constant DC link voltage. While the inverter converts the DC link voltage to the required AC in order to feed the load. During power failure, the Magnetic Contactor (MC) disconnects the AC line, but the inverter keeps supplying power to the load from the battery bank without any interruption. Thus the inverter keeps on operation in both the modes.

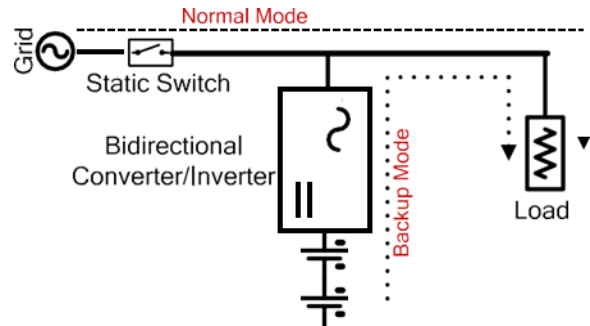

Fig. 2: - Block Diagram of Line Interactive UPS system.

2.4) Power problems and UPS solutions:

The power supplied by the grid is not always very clean and continuous. There may be some major faults in the system which leads to long interruptions and complete black out of the grid. Besides voltage swells and dropouts, voltage sag, harmonic distortion, etc. are other faults which are commonly encountered in the grid.

III. UPS SYSTEM WITH BIFRED CONVERTER

An improved UPS system using High frequency transformer is proposed. In this topology, boost integrated fly back rectifier/energy storage DC-DC converter (BIFRED) has been used, which maintains the constant DC link voltage in order to feed it to the inverter and conventional bidirectional converter is used to charge and discharge the battery. The circuit provides excellent power factor correction, and with high frequency transformer the size of the system is reduced considerable. But the battery bank voltage of the circuit will be increased significantly if the system is design for 220 V grid voltage.

IV. Z-SOURCE INVERTER BASED UPS SYSTEM

Another transformer-less UPS topology has been proposed in which utilizes a Z-source inverter. No dedicated boost converter has been used to step up the battery bank voltage as the Z source inverter combines the two stages of power conversions (DC-DC Step up converter and DC-AC inverter) into a single power conversion stage. Also a dual loop control scheme has

been used to increase the transient response time of the system. No dead time in the PWM signal is required to prevent the switches of the same leg turning ON at the same time. Thus the distortion in the AC output voltage is reduced considerable. Thirty batteries connected in series provide the 360 V DC voltage at the input of the DC voltage. So the battery bank is very high, and is only feasible for high power applications.

V. TRANSFORMER-LESS UPS SYSTEM

Now a days with the development of advanced microcontrollers, and advancement in the power electronics, transformer-less UPS are getting popularity in the market. These UPS are less costly, highly efficient, and most importantly smaller in size than the transformer-based UPS. But the transformer-less UPS still has also some major limitation which needs to be addressed. This type of UPS is more likely to be effected by the transients and spikes caused by miscellaneous devices connected to the main utility grid .The battery bank in transformer-less UPS is very high to achieve high DC link voltage, which increases the battery cost and lower the reliability of the system.

VI. RENEWABLE ENERGY INTERGATED UPS SYSTEM

Since global warming and greenhouse effect has reached to its threatening level, renewable energy is the only option for future energy requirement. Photovoltaic (PV) and wind energy are the most promising solution to supply energy in isolated areas. Uninterruptible power supplies with renewable energy resources connected with the utility grid provide more reliable and quality power to the connected load. UPS with PV system is shown in the fig 3. The PV module is connected to the system through the DC–DC converter while the batteries and super- capacitor are connected to the DC-Bus using bidirectional converter. The inverter supply AC voltage to the connected load. When there is a surplus energy available, it is stored in the connected battery bank and super capacitor. Under the conditions, when load demand exceeds the generation or during night time, the stored energy is utilized to fulfil the requirements of the load. Super

capacitor is added in the system to provide fast dynamic regulation of the power.

UPS with PV system helps in peak shearing, smoothing out load fluctuations, and making up for intermittent variation in renewable energy sources so as to make an efficient energy management in integrated systems.

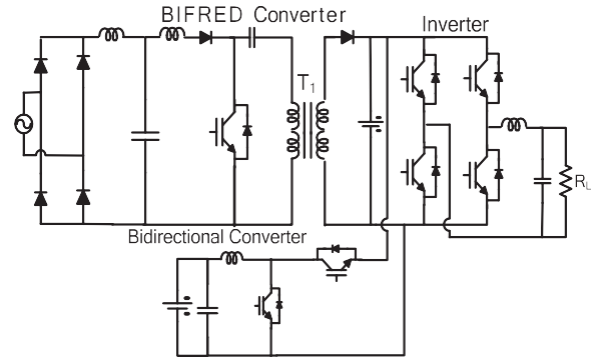

Fig. 3: - UPS system with BIFRED Converter

VII. CURRENT TRENDS IN UPS TECHNOLOGY

- 7.1) Voltage:
 - a. 3-ph, 4 W, 120/208V characterization for little furthermore, mid range sizes.
 - b. 3-ph, 480V arrangement is ordinary in bigger limit UPS systems.
 - c. 3-ph , 4 W, 230/400V ending up more generally utilized as a part of mid and substantial limit UPS.
 - d. New pattern, in substantial server farms using 575/600V dissemination grouping.
 - e. Medium voltage UPS dissemination in vast Offices
- 7.2) Technological progression of semiconductor control gadgets:
 - a. The Rising requirement for higher exchanging frequencies in control electronic applications.
 - b. The rise of the Insulated Gate Bipolar Transistor (IGBT) offers prevalent UPS execution and unwavering quality.

- c. 1992, began the utilization of full IGBT outline in both converter and inverter areas of UPS frameworks.
- d. IGBT devices are predominantly used in UPS inverter sections where the ability to switch the device on and off and control instantaneously is essential also IGBT controls allow optimum performance of the whole UPS system along with the connected devices.
- e. UPS use various configurations including full IGBT, Diode/IGBT hybrid combination or Silicon Controlled Rectifier (SCR) aka thyristor. And larger UPS Systems more likely to have IGBT/Diode front end design (for increased efficiency) or SCR rectifier.

VIII. NEXT GENERATION UNINTERRUPTIBLE POWER SUPPLY

In recent years, the concept of smart grid is getting famous and is considered as the next generation power grid. Electricity generation using sustainable energy is environmental friendly and can be added to the smart grid. The distributive generating system provides standby power during grid interruption and load sharing during peak hours, thus it helps in cost reduction and reliable power delivery. In fact the concept of distributive generation system falls into the category of the UPS system.

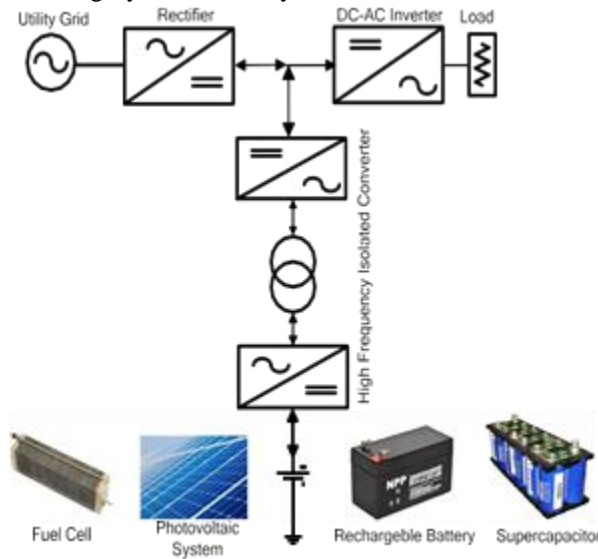

Fig. 4: - Block Diagram of Intelligent UPS system

An intelligent UPS system has been presented in for the smart grid which is energy saving, reliable and flexible for accommodation of DG sources. Fig. 4. shows the block diagram of the next generation UPS system. The UPS system has high frequency converter which allows the parallel connection of the batteries with other Distributive generation (DG) system to the smart grid. Hence the proposed UPS system in addition to traditional operation can also realize the cyclic use of electrical power between the power grid and storage system. Due to its modular structure, it can be applied to motor drive, auxiliary power supplies for hybrid electrical vehicles and DG system.

IX. SELECTION CONSIDERATION OF UPS SYSTEM FOR SPECIFIC APPLICATION

With so many choices of the UPS system available to choose from, which is the most suitable for your circumstances? Selecting a particular type and configuration of UPS depends upon the following factors. (1) Power requirement, (2) Power factor, (3) Cost, (4) Size and Weight, (5) Grid environment, (6) Reliability, (7) Protection, (8) Required level of Power quality, and (9) Size of the battery bank.

The Process of selecting a UPS system consists of seven steps.

- (1) Determining the need of UPS system,
 - (2) Calculating the Power requirement of UPS system,
 - (3) Selecting type of UPS system,
 - (4) Select configuration of UPS system,
 - (5) Safety of UPS system,
 - (6) Availability of UPS system,
 - (7) Is selected UPS system affordable.
- Fig. 26 shows the flow chart for selection of a UPS system for particular application.

X. DETERMINING THE NEED OF UPS SYSTEM

The selection of UPS system is strongly dependent on the application for which the system is chosen. Applications such as hospital life support and medical equipment, military equipment's, and communication devices cannot tolerate any power interruption even

for very short period of time. UPS system required for such application should provide backup until the utility grid power is restored. For data centres, the backup may require for only few moments until the devices are shutdown. Surveying the history of commercial outages by power companies can better provide statistics about selection of UPS system.

XI. FUTURE TRENDS

Further improvement in the UPS technology in terms of replacing the conventional storage with fuel cells will be a real boost for UPS in low power applications. Fuel cells have high specific energy, high reliability, and are environment friendly as compared to conventional storage systems. UPS systems that use the fuel cell in combination with the super-capacitor are also not that extensively investigated. Recognizing the advantages of the hybrid system, we can expect more advanced UPS system, with added functionality and better performance.

XII. CONCLUSION

In this paper a review of industrial uninterruptible power supply has been presented to explain the various current trends in uninterrupted power supply that are currently being used in large number of industries, having smaller and larger UPS systems.

Also, in present scenario many manufacturers are using hydrogen ion battery instead of using Li-polymer battery in storage units, by using hydrogen ion battery the overall efficiency of UPS system can be increased up to 100 times as that of Li battery. IGBTs are also being used in inverter section for instantly turn on and off the switch and the system reliability is also improved. A topological classification of the UPS system has been discussed with their performance, efficiency, advantages, and disadvantages. Comparative analysis of different systems and their control schemes have been presented to provide useful information, which helps in easy selection of control scheme for a particular application. Model predictive control shows excellent performance for the control of the inverter.

REFERENCES

- [1] Gurrero J, De Vicuna LG, Uceda J. Uninterruptible power supply systems provide protection. *IEEE Ind Electron Mag* 2007;1:28–38.
- [2] Windhorn A. A hybrid static/rotary UPS system. *IEEE Trans Ind Appl* 1992;28:541–5.
- [3] King A, Knight W. *Uninterruptible Power Supplies and Standby Power Systems*. McGraw-Hill; 2003.
- [4] El Fathi A, Nkhaili L, Bennouna A, Outzourhit A. Performance parameters of a standalone PV plant. *Energy Convers Manag* 2014;86:490–5.
- [5] De Bernardinis A, Péra M-C, Garnier J, Hissel D, Coquery G, Kauffmann J-M. Fuel cells multi-stack power architectures and experimental validation of 1kW parallel twin stack PEFC generator based on high frequency magnetic coupling dedicated to on board power unit. *Energy Convers Manag* 2008;49:2367–83.
- [6] Per Grandjean-Thomsen. *UPS System Design Handbook*. Merlin Gerin (Aust) Pty Limited. 1992.
- [7] Deng H, Oruganti R, Srinivasan D. Modeling and control of single-phase UPS inverters: a survey. *IEEE International Conference on Power Electronics and Drives Systems, 2005 PEDS*; 2005. p. 848-53.
- [8] Niroomand M, Karshenas H. Review and comparison of control methods for uninterruptible power supplies. 2010 1st: *IEEE Power Electronic & Drive Systems & Technologies Conference (PEDSTC)*; 2010. p. 18-23.
- [9] Solter W. A new international UPS classification by IEC 62040-3. 2002 *IEEE INTELEC 24th Annual International Telecommunications Energy Conference*; 2002. p. 541-5.
- [10] Racine MS, Parham JD, Rashid M. An overview of uninterruptible power supplies. *Power Symposium, 2005 Proceedings of the 37th Annual North American: IEEE*; 2005. p. 159-64.
- [11] Bekiarov SB, Emadi A. Uninterruptible power supplies: classification, operation, dynamics, and control. *Applied Power Electronics Conference and Exposition, 2002 APEC 2002 Seventeenth Annual IEEE: IEEE*; 2002. p. 597- 604.
- [12] Karve S. Three of a kind [UPS topologies, IEC standard]. *IEE Rev* 2000;46:27– 31.
- [13] Kwon B-H, Choi J-H, Kim T-W. Improved single-phase line-interactive UPS. *IEEE Trans Ind Electron* 2001;48:804–11.
- [14] Holtz J, Lotzkat W, Werner K-H. A high-power multitransistor-inverter uninterruptible

power supply system. IEEE Trans Power Electron 1988;3:278–85.

- [15] Botterón F, Pinheiro H. A three-phase UPS that complies with the standard IEC 62040-3. IEEE Trans Ind Electron 2007;54:2120–36.