

Power Quality Improvement Using Closed Loop DC-DC Converter

MOHAMMAD AMIR ANSARI¹, ASHUTOSH YADAV², ASHISH SINGHAL³

^{1,2,3} Dept. of Electrical Engineering, Sagar Institute of Science, Engineering and Technology, Bhopal

Abstract -- This paper presents a study on utilization of DC-DC converter in the renewable energy system like wind turbine. Basically all DC-DC converters are based on two models i.e. Buck and Boost. The aim here to use DC-DC converters is to reduce the size, cost and losses.

In the present scenario we need power of better quality i.e. noise, ripple content and harmonics should be as minimum as possible. These aims can be better satisfied by using DC-DC converters. Higher efficiency of DC-Dc converters makes it extremely useful in modern energy conversion systems.

Indexed Terms -- DC-DC Converter, MATLAB, Voltage Control

I. INTRODUCTION

In the current global climate demands for renewable energy system has increased due to environmental issues and limited fossil resources so however, to connect these systems to the grid, output voltage and frequency adjustment are the challenging issues. Various types of converters have been utilized to provide grid connected renewable energy system.

A DC-DC converter is employed in this paper to generate desired voltage and frequency for a grid connection. As well an AC-DC-AC converter is necessary for wind turbine as wind energy is variable during the operation. In response to growing demand for medium and high power applications, multi-level inverters have been attracting growing consideration recently Multilevel converters enable the output voltage to be increased without increasing the voltage rating of switching components So that They offer the direct connection of Renewable energy system to grid voltage without using Expensive Bulky and Heavy Transformers.

II. VARIABLE SPEED WIND TURBINE SYSTEM

This topology basically employs induction or synchronous machine as a generator. The power electronics converter in this topology might be created by either a diode rectifier with boost chopper converter connected to the PWM inverter or two bidirectional PWM-VSI connected back-to-back converter.

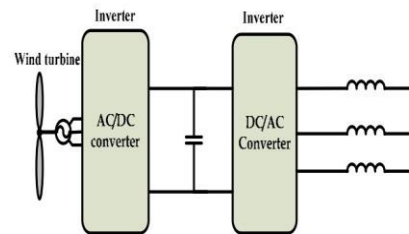

Fig. 1: - Power conversion in WT systems using back-to-back configuration.

An alternative to the power conversion system of a wind turbine is to use synchronous or permanent magnet generator instead of the induction machine as shown in Fig. The power converter in generator side is replaced by an AC-DC rectifier with step-up DC-DC converter. This is a low cost configuration when compared with back-to-back topology. As the wind energy is variable, the step-up converter is responsible to adapt the rectifier voltage to the DC link voltage of the inverter. Also, this structure may provide transformer less connection systems due to the DC level voltage regulation using boost converter. Using multilevel converters for medium and high voltage applications is advantageous based on this structure as they can increase the voltage without increasing the switching components voltage rate.

III. CONVERTER

DC-DC converters are a kind of high frequency converters, which convert unregulated DC power to regulated DC power. Since the output voltage of renewable energy systems or rectifier converter is basically unregulated DC voltage, as shown in Fig. DC-DC converters are necessary to adjust the DC voltage for different applications. Three basic configurations of DC-DC converters are buck, boost and buck-boost converters.

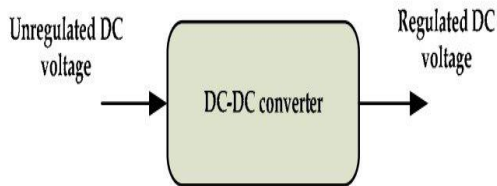

Fig. 2: - Basic DC- DC Converter Configuration

In a buck converter the output voltage is normally less than input voltage. However, a boost converter has the ability to increase the input voltage based on duty cycle of the switch. A buck-boost converter can either buck or boost the input voltage. A boost converter is usually applied in renewable energy systems as the output voltage of these systems is low and unregulated. Configuration of the boost converter is illustrated in Fig. In this converter, output voltage is a function of the duty cycle of switch (S), which can be defined by a proper modulation technique. When the switch is on, current flowing through it can charge the inductor. However, in the next subinterval when the switch is turned off, the inductor current will charge the capacitor. Second order LC filter in this configuration can regulate the output voltage and remove the high frequency harmonics.

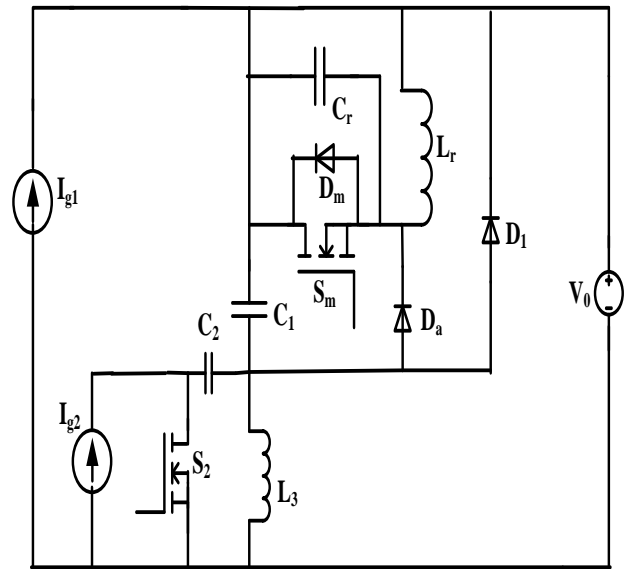

Fig. 3: - Schematic configuration of a DC-DC converter

3.1 Classification of DC-DC converters:

Normally, the converters are designed in the medium frequency range. The various types of converter are buck converter, boost converter. There are different modes of operations comes into picture such as continuous conduction mode (CCM), discontinuous conduction mode (DCM).

3.2 Simulation:

MATLAB plays a vital role in the design and analysis of the converters. Various types of software are used to simulate those converters in the initial level. Different types of software are MATLAB, PSIM, PSPICE. There are also different simulations approaches are used for detailed studies such as device level simulation, circuit level simulation and system level simulation. Another classification is device level simulation and ideal level simulation. Different analyses which are available in different simulators are dc analysis (steady state analysis), ac analysis (variation in the parameters), and transient analysis (large-signal analysis).

3.3 ADVANTAGE:

The advantages of MATLAB are: it is possible to study the effects of variations in linear and non-linear elements. There is a provision to obtain “fourier analysis” without using expensive wave form analyzers. It is possible to have optimum design of power electronics circuits. It is possible to identify the performance improvements and/or degradations. Evaluation of the effects of noise and signal distortion without the need for expensive measuring instruments is possible.

3.4 Filter:

All power electronics converters are nothing but filters. Different types of filters give specific name for our convenient. While designing the filters, maximum power transfer theorem is applied to power electronics circuit. Filters can be designed for input port as well as output port. Filters can be classified based on different categories. Based on the frequency, the filters are classified as: low pass filter, high pass filter, band pass filter, band stop filter. Frequency range is related to the amount of power processing in the converters. So filter designs plays an important role in the converter circuit.

3.5 Controller:

As we have said the controller is the brain of the converter where the converter is treated as the heart. The converter produces a desired output which is required for the load connected at the output of the converter. Due to the disturbances occur in the converter, the load always not getting the constant desired output. Sometimes, the converter goes unstable which affects the load. So to maintain the required output constant, controller is needed. There are various kind of controllers used in the converter to improve the stability as well as the efficiency. The aim of all type of controllers is to operate the converter in the desired output range and there should be minimum effect due to the external disturbances.

3.6 Recent Converters:

The recent converters are the modifications of the basic converter which increases the operating regions. The converters can be modified by adding inductor and capacitor which increases the order of the

converters. Some examples are adaptive hysteresis control of 3rd order buck converter, predictive controller for fourth order buck converter etc. Multi-input converter can be obtained by adding more than one input sources in the converter. So rigorous study is required by applying different control methods.

3.6.1 Bidirectional Converter:

One such type of converter is bidirectional buck-boost converters. In this type of converters, one direction is used to step-up the voltage and another direction is used to step-down the voltage. It is like the charging and discharging of the converter. It can be operated in CCM as well as DCM.

The Fig.1 shows one of the bidirectional dc-dc converter. It is using four controlled switching devices. The left side of the converter is used as high voltage side and right hand side is used as low voltage side. Two capacitors with same rating are used in the high voltage side to maintain the half of the input voltage constant. A lot of work is done for designing the converter. But few work has been done for controlling this converter. The logic can be developed where the converter can operate buck or boost mode where the power is flowing from left to right. Similarly, the logic can also be developed to operate the converter in buck as well as boost mode during right to left power flow. The converter is studied in CCM mode and DCM mode which can be extended to PCCM mode.

IV. ANALYSIS OF CONVERTER WAVEFORMS

Under steady-state conditions, the voltage and current waveforms of a dc-dc converter can be found by use of two basic circuit analysis principles. The principle of *inductor volt-second balance* states that the average value, or dc component, of voltage applied across an ideal inductor winding must be zero. This principle also applies to each winding of a transformer or other multiple winding magnetic devices. Its dual, the principle of *capacitor amp-second or charge balance*, states that the average current that flows through an ideal capacitor must be zero. Hence, to determine the voltages and currents of dc-dc converters operating in periodic steady state, one averages the inductor current

and capacitor voltage waveforms over one switching period, and equates the results to zero.

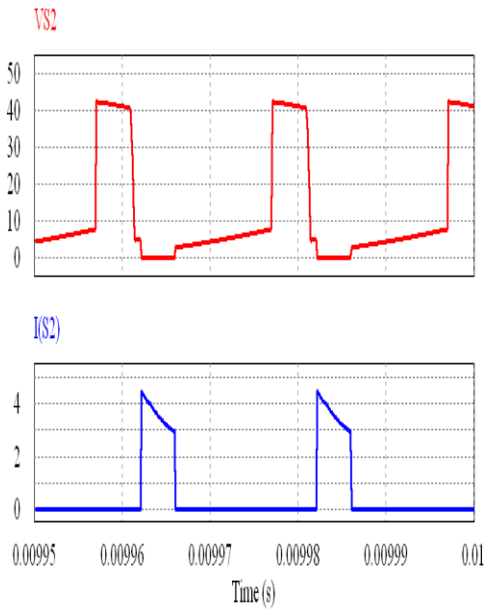

Fig. 4: - Open Loop Waveform

A sudden source disturbance of 36 to 40 V for first source and 12 to 16 V for second source has been created in the source voltages after 15 ms and the controller action made the converter to regulate the voltage and also found the controller action to be satisfactory which made the transients to die down. The corresponding results shown in Fig. 4.

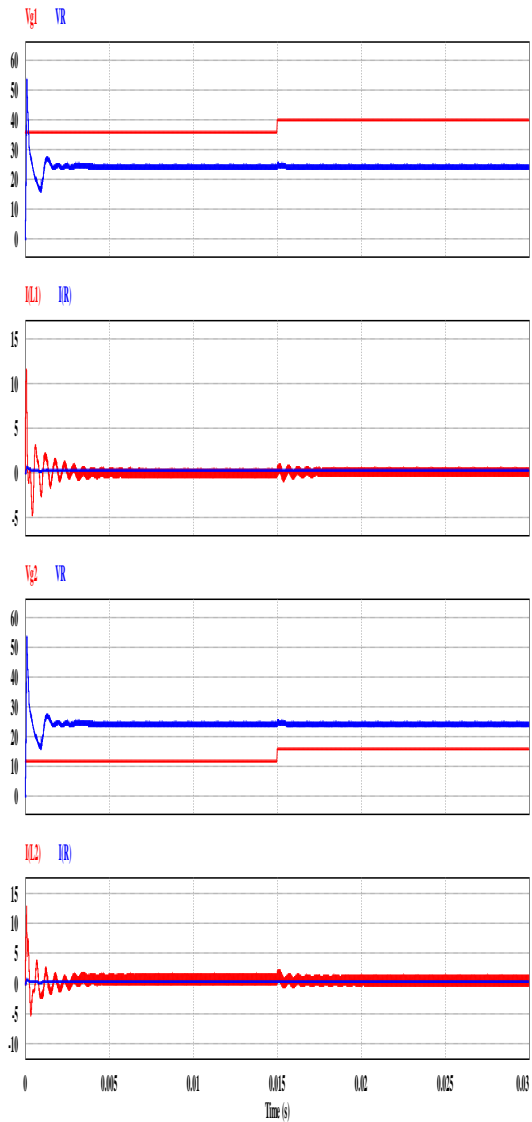

Fig. 5: - Simulated dynamic response characteristics of the converter ($V_{g1} = 36 \rightarrow 40 V$ and $V_{g2} = 12 \rightarrow 16 V$).

The capacitor voltages contain dc components, plus switching ripple at the switching frequency and its harmonics.

V. CONCLUSION

By using DC-DC converter in renewable energy applications we have reduced the power quality problems, losses and cost. Here we use the boost converter because the voltage obtained from the wind turbine is low and unregulated.

REFERENCES

- [1] Pradipta Patra, Amit Patra, and Neeraj Misra, "A Single-Inductor Multiple-Output Switcher With Simultaneous Buck, Boost, and Inverted Outputs," *IEEE Trans. on Power Electron.*, vol. 27, no. 4, pp.1936-1951, April 2012.
- [2] Shih-Ming Chen, Lung-Sheng Yang, Tsorng-Juu Liang, and Jiann-Fuh Chen, "A Cascaded High Step-Up DC-DC Converter With Single Switch for Microsource Applications," *IEEE Trans. on Power Electron.*, vol. 26, no. 4, pp.1146-1153, April 2011.
- [3] Chuan Yao; Xinbo Ruan; Xuehua Wang; , "Isolated Buck-Boost DC/DC converter for PV grid-connected system," *Industrial Electronics (ISIE), 2010 IEEE International Symposium on* , vol., no., pp.889-894, 4-7 July 2010.
- [4] Tan, N.M.L.; Abe, T.; Akagi, H.; , "Design and Performance of a Bidirectional Isolated DC-DC Converter for a Battery Energy Storage System," *Power Electronics, IEEE Transactions on* , vol.27, no.3, pp.1237-1248, March 2012.
- [5] F. Blaabjerg, Z. Chen, and S. B. Kjaer, "Power electronics as efficient interface in dispersed power generation systems," *IEEE Trans. Power Electron.*, vol. 19, no. 5, pp. 1184-1194, Sep. 2004.
- [6] Matsuo, Hirofumi; Kurokawa, Fujio; , "New Solar Cell Power Supply System Using a Boost Type Bi directinal DC-DC Converter," *Industrial Electronics, IEEE Transactions on* , vol.IE-31, no.1, pp.51- 55, Feb. 1984.
- [7] S. Cuk, Basics of switched-mode power conversion: topologies, magnetics, and control, in *Advances in Switched-Mode Power Conversion*, vol. 2, pp. 279-310, Irvine: Tesla co, 1981.
- [8] R. W. Erickson, *Fundamentals of Power Electronics* NewYork: Chapman and Hall, 1997.
- [9] V. Vorperian, R. Tymerski, and F. C. Lee, Equivalent circuit models for resonant and PWMswitches, *IEEE Trans. Power Electron.*, vol. 4, no. 2, pp. 205-214, April 1989.
- [10] G. W. Wester and R. D. Middle brook, Low frequency characterization of switched dc-dc converters, *IEEE Trans. Aerosp. Electron. Syst.*, vol. AES-9, pp. 376-385, May 1973.
- [11] Moshirvaziri, M.; Chuanwei Li; Trescases, O.; , "A quasi-resonant bi-directional tri-mode DC-DC converter with limited valley current," *Applied Power Electronics Conference and Exposition (APEC), 2012 Twenty-Seventh Annual IEEE* , vol., no., pp.517-523, 5-9 Feb. 2012.
- [12] Kuiyuan Wu; de Silva, C.W.; Dunford, W.G.; "Stability Analysis of Isolated Bidirectional Dual Active Full-Bridge DC-DC Converter With Triple Phase-Shift Control," *Power Electronics, IEEE Transactions on* , vol.27, no.4, pp.2007-2017, April 2012.
- [13] Stahl, G.; Rodriguez, M.; Maksimovic, D.; , "A high-efficiency bidirectional buck-boost DC-DC converter," *Applied Power Electronics Conference and Exposition (APEC), 2012 Twenty-Seventh Annual IEEE* , vol., no., pp.1362-1367, 5-9 Feb 2012.
- [14] Yu Du; Huang, A.Q.; Mengqi Wang; Lukic, S.M.; , "A novel high step-up ratio bi-directional DC-DC converter," *Applied Power Electronics Conference and Exposition (APEC), 2012 Twenty-Seventh Annual IEEE* , vol., no., pp.524-531, 5-9 Feb 2012.