

# Smart Real-Time Drainage Monitoring System Using Internet of Things

GAURANG SONAWANE<sup>1</sup>, CHETAN MAHAJAN<sup>2</sup>, ANUJA NIKALE<sup>3</sup>, YOGITA DALVI<sup>4</sup>

<sup>1,2,3,4</sup> Dept. of Computer Engineering, Late G. N. Sapkal College of Engineering, Nashik

**Abstract --** Drainage system monitoring plays an important role to keep city clean. In fact, not all areas have drainage monitoring team. It leads to irregular monitoring of the drainage condition. The irregular monitoring leads to the blocking of the drainage that imply to the salutation which trigger flood. Manual monitoring is also incompetent. It requires a professionals but they can only monitor very finite and maintain low accuracy. Also sometimes due to lack of knowledge the worker may meets to an accident as they have no idea that how will be the conditions in those manhole. This paper represents the application and design function of a smart and real-time Drainage and Manhole Monitoring System with the help of Internet of Things. The manholes present in the drainage will have a module which is having microcontroller interfaced with gas sensor, level indicator, NRF. The system will monitor if the blockage is occurred in between two manholes and also it will sense the rise in amount of various gases which are harmful to the human beings, and also a system of monitoring the water level then it will trigger an alarm and will provide those information to the health departments from which the particular action will be taken. The system will able to monitor all these things in real-time scenario which will allow us to take proper actions of the particular problem in drainage system.

**Indexed Terms --** Smart real-time Drainage Monitoring, Internet of Things (IoT), wireless sensor networks (WSN), NRF, Gas Sensor, Blockage, IoT applications WSN optimized design, WSN platform, WSN protocol.

## I. INTRODUCTION

Drainage system plays a very important role in big cities where millions of people live. Drainage system is known as the base for land dryness from the excess and unused water. Rain water and waste water. Drainage conditions should be monitored in order to maintain its proper function. In fact, not all areas have drainage monitoring team. It leads to irregular monitoring of the drainage condition. The irregular monitoring has contribution on the blocking of the drainage that imply to the salutation which trigger flooding in the neighborhood. Manual monitoring is also incompetent. It needs a lot of dedicated persons who are only able to record limited report with low

accuracy. The problem arises in such drainage lines can cause serious issues to the daily routine of the city. Problems such as blockage due to waste material, sudden increase in the water level as well as various harmful gases can be produces if the proper cleaning actions are not taken time to time. Today's drainage system is not computerized due to which it is hard to know if blockage is occurring in particular location. Also sometimes due the waste in those drainage lines can produce various gases like methane (CH<sub>4</sub>), carbon monoxide (CO), etc which are harmful and can cause serious problem if inhaled by humans in large amount and these problems are generally faced by the drainage workers due to which death can occurs. Also we don't get early alerts of the blockage or rise in amount of those gases or the increase in water level. Hence detection and repairing of the blockage becomes time consuming and hectic. WSN is a monitoring technology which inhere of node sensors that expanse and integrate use of a wireless network system. Every node consist the data processing (microcontroller, eg - Arduino) memory (program, data, flash memory), NRF transceiver, power supply system and involves one or more sensors. WSN systems have a higher level of precision than wired network system with respect to cost; flexibleness and reliability are expected to replace hybrid or combined technology.

## II. RELATED WORK

The deployment of WSN on numerous applications areas such as conveying, logistics, environmental and surrounding monitoring, security and supervision, industrial, automation, military, agriculture and health related works has been reported. [2] Use of WSN to monitor volcanic activities. [3] Predictive flood detection system using IoT are implemented in river like Honduras and other rivers [7]. WSN can be useful

in design of environmental monitoring systems in developing countries. [4] Designed a predictive disaster and alert generation system using WSN to provide weather information and early alerts.

Smart city infrastructure could be in terms of intelligent traffic signals, sensors, active lanes, communication, and so on. Thus, smart devices when integrated into the city's infrastructure through the effective deployment of ICT, can make life in a city a lot easier.

In this paper, we design smart real-time drainage monitoring system using various sensors such as water level, blockage and gas sensor. The water level will determine the extent of the flood as low, medium or high. This will enhance early flood detection. The gas sensors are used to measure the amount of various hazardous gases by which drainage workers can take precautions while entering in manholes. The blockage sensors will detect the blockage in the sewer lines and provides the early alarms so that we can clean it as early as possible.

1. Why Smart Drainage System is essentially needed? –

Objectives:

- Predictive drainage clogging system: The intelligence of sensors and predictive system identifies the drain clogged spot and gives us the details for further actions to take.
- Completely connected: The sensors are communicated through communication modules to share information.
- The main objective of this project is to keep the city clean, safety and healthy. And replace the manual work of drainage monitoring for the safety of sewer workers, human and city.
- To help proprietors, contractors and workers to prevent gas poisoning in drainage work.

### III. PROPOSED SYSTEM

The smart drainage system will have:

1. Sensors to detect blockage, flood and gases.

2. The intelligence of sensors and system will identify the clogging inside the drainage system and will give the details of the location and other information for further actions.
3. The system will also sense the presence of various harmful gases such as Methane (CH<sub>4</sub>), Sulfur dioxide (SO<sub>2</sub>), Carbon monoxide (CO) etc.
4. As the level of such gases pass the threshold value the system will generate the alert using alarm system by which the Health department will take proper action on it.
5. The module is implemented using Wireless Sensor Networking (WSN) technology each node will carry its own data along with the data of neighboring node and will pass it to next node by hopping techniques.
6. These entire data packet will be collectively sent by the gateway node and stored at the cloud all these data will be accessible in real-time scenario for continuous monitoring.

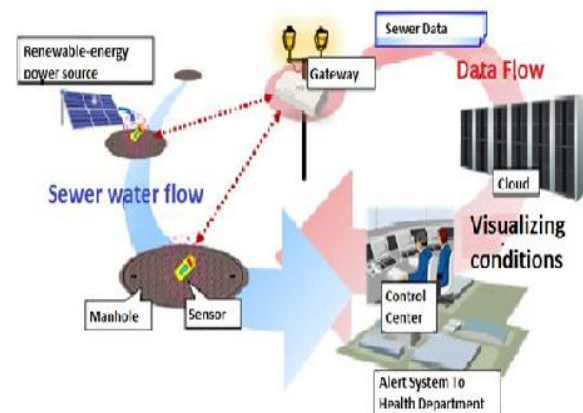

Fig. 1: - Proposed System

Using our smart drainage system we can easily monitor, modify and rectify the problems in real time.

### IV. WORKING PRINCIPLE

The drainage channels are covered with manholes to operate and to clear the blocking present inside the channel. By placing the sensor node inside of the manhole will detects and transfers the appropriate sensed information about the blockage, harmful gases and conditions to detect elevated flow levels of drainage system. Using the communication modules it

will communicate with the sensor nodes placed at nearby manholes. This data will be then transmitted to the base station for further analysis.

Sensors will monitor the water levels, blockage in drainage as well as amount of hazardous gases in real-time scenario. Based upon the data values given by the sensors in drainage system the information along with location ID will send to the Gateway and that sends to cloud (server) or concerned authority.

V. SENSOR UNIT

Based on drainage monitoring guidelines, the monitoring parameters are monitored.

1. Blockage in between two manholes.
2. Detection of hazardous gases.
3. Detection of water level.

So the sensor that we need is water level sensor, sensor for blockage detection and gas detection sensor. Water level sensor is used to determine the water level. If the water level increases while the rainfall and water discharge normal it means that occurs salutation in the channel. Similarly the gas sensor is used to measure the presence of particular gases as well as amount of those gases. Various gas sensors are MQ3, MQ6 etc; which are used to sense the gases such as carbon monoxide (CO), sulfur dioxide (SO2), methane (CH4).

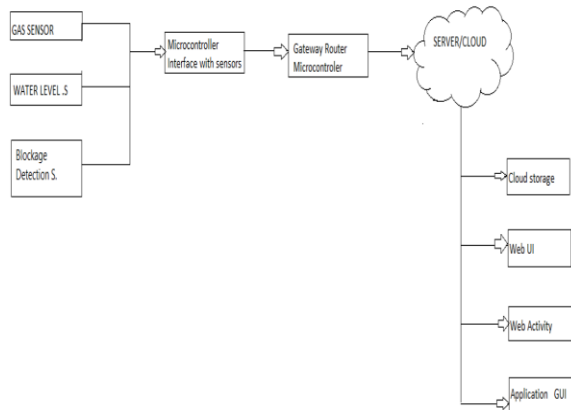

Fig. 2: - Component diagram for sensors

This figure below shows component diagram for the sensors which are used in a single node for the system.

VI. HARDWARE OF NODE SENSOR AND GATEWAY

Hardware on the node includes sensors, signal conditioning, gas sensor, raindrop sensor, processor, RTC (Real time Clock), RF (Radio Frequency) modules and supply units. The RF module that used is NRF. This module requires minimal power and provides reliable delivery of data between remote devices. The modules operate within the ISM (Industrial, Scientific and medical) 2.4GHz frequency band. The output of water level sensors, gas sensor and blockage sensor conditioned as standard input signal for microcontroller. Output of signal conditioning will be input to the internal ADC (Analog to Digital Converter) of Microcontroller. RTC set the time of data collection and then RF Module (NRF) send the data to other sensor nodes. Supply unit can be either battery or solar cell give the power to the sensor node.

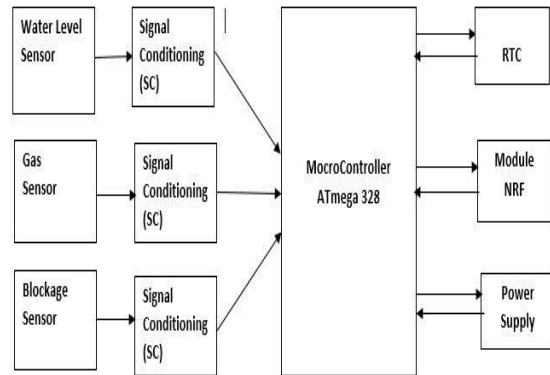

Fig. 3: - Block diagram for the sensor nodes

The gateway is sensor node that has additional functions to send data to the server. The communication mode that used in this design is GSM/Wifi connection. This component is used to send the entire collected data packet to the cloud where it is stored for further use. The figure below shows the block diagram of gateway node.

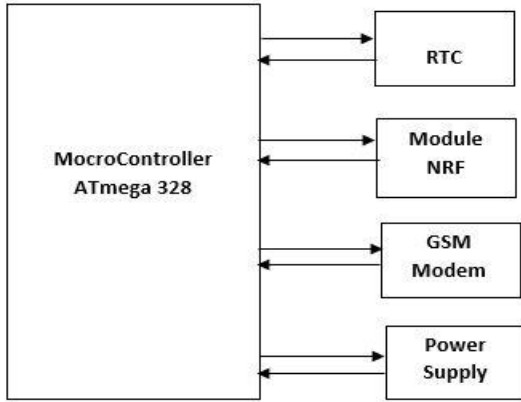

Fig. 4: - Gateway node diagram.



Fig. 5: - Sensing and routing node pcb

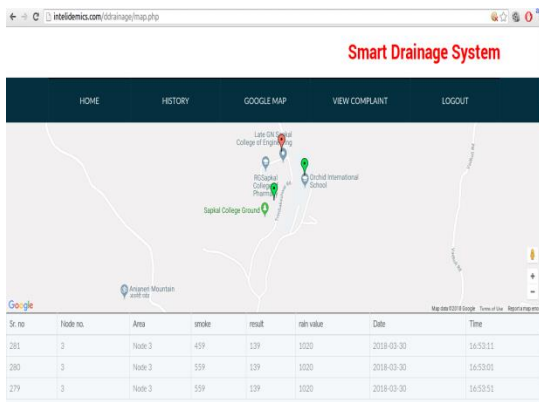

Fig. 6: - Google map GUI location alarm signal view

### VII. OPERATING SCENARIO AND THE NODE AND NETWORK ARCHITECTURES

Sensors from all nodes will sense the gas and water levels at particular time intervals this data is hopped from node 1 to node 2 and node 2 to node 3 by using

NRF modules mounted on every node for node to node data communication the third node is router node which is equipped with additional wifi/gsm module for data transmission to server then this information is fetched from server and if analyzed and if any sensed values crosses the threshold value then it will generate an alarm on display screen and the detail intensity levels and location information are displayed. Red color will indicate the alarm and green will indicate the intensity levels are below threshold.

### VIII. ENERGY HARVESTING TECHNIQUES FOR SENSOR NODES

Many papers focus on the use of renewable energy sources to power sensor nodes. Solutions exploiting radio frequency and mechanical vibrations are not suitable for underground environments such as the proposed scenario. Nevertheless, this kind of source is often exploited to power low consumption systems such as sensor nodes. Regarding the use of solar power it is necessary that the outer cover of manhole is directly exposed to the sunlight. Moreover, if Arduino micro-controller is used as the core of the sensor node, a plug-and-play solar charger shield is commercially available. Multiple hybrid batteries are also available which can power up the node for several months.

### IX. DATA ACQUISITION AND TRANSMISSION SYSTEMS

In this section, all the sensors used for the monitoring as well as the transmission system, are described. Our system consist four sensors. MQ2, MQ3, MQ7 and water level sensor. The above sensors senses the intensity levels of water level , smoke and gases such as carbon monoxide ,lpg, alcohol benzine CH4, Hexane, CO Propane.NRF communication modules are used for node to node communication shown in fig no 5.GPRS/Wifi modules are used for sending sensed data to cloud. Offline texts sms are also sent from web to the given predefined mobile number with node information and alert.

## X. SYSTEM TESTS AND RESULTS

### 1. Hardware testing:

While the data transmission system has been tested at our workshop at Nashik, the overall sensor node architecture has also been tested in one of the few open air parts of the Nashik city so as to ease all the test procedures. Regarding the communication channel, the data transmission was tested with the sensor nodes powered by a common battery, and the 10 feet data transmission range was fully achieved, confirming the feasibility of the whole network architecture. For the testing of the sensor node, the support structure has been placed close to the duct of the manholes and many water drainage systems. The height of the water level has been carefully regulated and obtains the good test results. Nevertheless, it has to be underlined, that with different depth values of the water level sensor the variation of the levels is achieved. This fact suggests that the node will be able to operate also with variable water levels. The gas sensors are also found working in hazardous condition where higher concentration of gases is present. All the sensors detect the values and the router node sends the data to cloud and live intensity levels are displayed on the website. And when the intensity levels exceed the threshold the alarm is given and displayed with location and intensity details. As we are using a WiFi module thus it is secured by security protocols such as WPA, WPS and WPA2.

### 2. Software testing:

Additional diagnostics and debugging of the Arduino codes are done by Proteus tool and good results are achieved. Efficiency and the flexibility of the Arduino programs is also checked using Proteus. The codes are error free and run efficiently on boards at real-time. Real-time simulations are also done of our system before its implementation and good results are achieved.

## XI. RESULT ANALYSIS

Sensor unit senses all the physical parameters like Gas intensity, water level, blockage, smoke due to release of chemical and gases inside the manhole and convert these inputs into electrical output, this electrical output received as an input to Arduino and is embedded with

gprs/wifi modules and programmed in such a way that all the information is sent to server in specific time intervals then the website displays all live readings of every node and the alert information into readable text in chart. Offline text SMS are also sent to the given predefined mobile number with node information and alert.

## XII. CONCLUSION AND FUTURE SCOPE

Sensor networks are considered as the key enablers for the IoT paradigm [1]. This paper addresses all about smart and real-time Drainage monitoring system through IoT applications for metropolitan cities. By using various sensors such as gas detection, water level as well as blockage detection we can monitor the real-time scenario of drainage system by detecting the problems in drainage system. By doing this we can be able to take particular action on the problems as we will receive the early alerts of blockage as well as increase. This paper can be used to design the smart and real-time drainage system for monitoring as well as troubleshooting purpose.

## REFERENCES

- [1] Brown, Eric (13 September 2016). "Who need the Internet of things". Linux.com. Retrieved 23 October 2016.
- [2] Wemer-Allen, G., Johnson, J., Ruize, M., Less, J., and Welsh, Matt "Monitoring Volcanic Eruptions with a Wireless sensor Network. (ISSN: 2321 – 5658) Volume 01– Issue 04, December 2013 Asian Online Journals
- [3] Basha, D. and Rus, D. "Design of Early Warning Flood Detection System for developing countries. Proceeding of the conference on ICTD, Bongsalove, India. Pp 1-10, 2007.
- [4] Yuwat, C. and Kilaso, S. "A Wireless Sensor Network for Weather and Disaster Alarm System", IPCSIT Vol. 6, Singapore. Pp 1 – 5, 2011
- [5] Morias, R., Valente, A., Serodo, C. "A Wireless Sensor Network for Smart Irrigation and Environmental Monitoring.

- EFTA/WCCA Joint Congress on IT in Agriculture, Portugal, pp 845 – 850. 2005
- [6] Windarto, J.” Flood Early Warning System develop at Garang River Semarang using Information Technology base on SMS and Web”. International Journal of Geomatics and Geosciences Vol. 1 No. 1, 2010
- [7] Wirawam, S., Pratoma, I., and Mita, Nagahisa. “Design of Low Cost Wireless Sensor Network-Based Environmental Monitoring System for Developing Country”. Proceedings of APCC 2008.
- [8] Retno Tri Wahyuni<sup>1\*</sup> Yusmar Palapa Wijaya<sup>2</sup> Dini Nurmalasari “Design of Wireless Sensor Network for Drainage Monitoring System” Vol.5, No.5, 2014

WEB REFERENCES:

- [1] G.H Rao President - Engineering And R&D Services (ERS) “Smart Cities Can Improve The Qua y Of Urban Life” January 30, 2015