

Variable Frequency Drive Based Speed Control of 3 Phase Induction Motor in Sugar Mill Using PLC AND SCADA

SHUBHA KULKARNI¹, DEEPIKA², ASHA³, KAVYA⁴, PRIYANKA. N⁵

^{1,2}Dept. of Electrical and Electronics Engineering, GNDEC, BIDAR

Abstract -- The Variable Frequency Drive(VFD) based speed control of three phase induction motor using PLC(Programmable Logic Controller) and SCADA(Supervisory Control and Data Acquisition system) involves a sugar plant. The sugar plant contains various stages involved in the production of sugar starting from the inflow of sugarcane into the crushing machine. The speed of the sugarcane crushing machine depends on the amount of sugarcane flowing into the machine. When the conveyor which supplies the sugarcane increases its speed then the load on the machine increases automatically.

Now-a-days in sugar plant, if heavy load enters into the crushing machine it cannot crush properly. So the wastage is increased and production rate will be reduced. To overcome this problem, we are going to implement the VFD based speed control of 3 phase induction motor. The whole unit is controlled by PLC and monitored by SCADA.

Indexed Terms -- Supervisory Control and Data Acquisition (SCADA), Programmable Logic Controller (PLC), Variable frequency drive (VFD), Motor.

I. INTRODUCTION

The most commonly used motor in sugar industry is three phase Induction Motor (IM) as it require very less maintenance. To alter the speed and rotating direction of the three phase induction motor Variable Frequency Drive(VFD) is used in the present years. In order to control and monitor the speed through Variable Frequency Drive, Programmable Logic Controller and Supervisory Control and Data Acquisition system are used. Automation of Variable Frequency Drive (VFD) based sugarcane crusher system consists of the following two main sections: Speed control using VFD, PLC-SCADA based Induction motor drive control.

The three-phase induction motor is used in a VFD system. As induction motor runs only at a steady speed rate so VFD is attached so that it can run at a varying speed. The VFD controller is a power electronics conversion system, which has an AC to DC converter, a buffer and filter link, and a DC to AC converter. The DC link in the VSI drive has a capacitor that will eliminate the noise distortion from the converter's DC output and a good signal without any warp is given as input to the inverter. With the help of inverter's Active switching element the filtered DC voltage is converted to quasi-sinusoidal AC voltage output. VSI drives supply higher power factor and lower harmonic distortion.

The advantages of VFD are that they are energy saving, consumes less current for starting of motor, thermal and mechanical losses are less on motors, maintenance is not required often, has high power factor and a low KVA. The PLC controls and monitors VFD and VFD acts as a conciliator between 3phase induction motor and the PLC. A conveyer is connected to the induction motor and cell sensor input is connected uniformly across the conveyer. The sensor input is connected to the PLC. This processes the input according to the ladder logic programming and initiates corresponding output to the VFD.

II. BLOCK DIAGRAM

The figure shows the block diagram of variable frequency drive speed control of three phase induction motor in sugar mill using PLC and

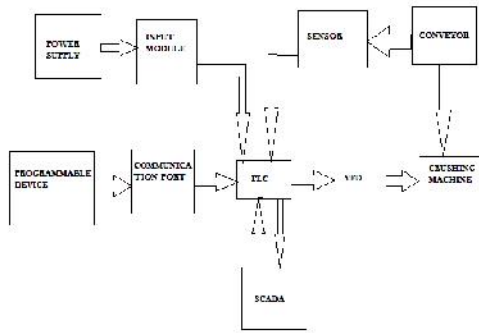

Fig. 1: - Sugarcane Crushing Machine Control

Switched mode power supply(SMPS) is used to convert ac to dc or dc to ac power supply. Using SMPS (Single Mode Power Supply) we are converting 230V AC to 24V DC power supply & given to the input field device. The input to the crushing machine is conveyed through a conveyor belt consisting of sensors. The weight of the sugarcane is sensed by the sensors and a signal is given to the PLC. This signal acts as the on/off deciding factor. The output from the PLC is interfaced with is VFD. This gives a variable frequency based on the input load. The output signal from the VFD is connected to the crushing machine. The speed and the frequency vary with respect to the load. The entire process is monitored by SCADA and controlled by PLC.

Among the electrical quantities, the sine wave frequency is probably the most complicated to change. Today there are two usual ways to do this, either by rotary motor-generators or by electronics. Rotary converts can convert between fixed frequencies like 50 to 60 Hz, or DC (0Hz) to AC and the opposite, but if the frequency needs to change often/dynamically like in servo motors, it can only be done by electronics.

III. WORKING

PLC's are designed to be operated by plant engineers and maintenance personnel with limited knowledge of computers. But unlike the computer, the PLC is programmed in LADDER LOGIC (A high level, real

world, graphic language that is easily understood by engineers).

SCADA is (intouch) the quickest and easiest way to create human machine interface (HMI) applications for the micro soft Windows 95 and Windows NT operating systems. In intouch is a component of the wonder ware factory suite.

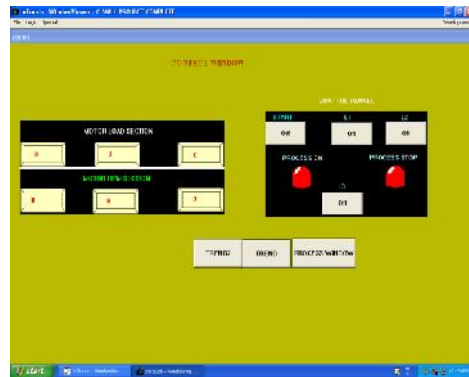

Fig. 2: - Control Window in off position

The motor load section, Motor RPM section, control panel are all available in the control window and is shown in fig.2. In this control window both the loads are in off condition. The motor RPM will change depends upon the Load given to the conveyor. If load increases, the speed of motor will decrease and if the load decreases, the motor RPM will increase.



Fig. 3: - Control window in on position

The motor load section, Motor RPM section, control panel are all available in the control window and is shown in fig.3. In this control window the load-1, load 2 and load 3 are in ON condition, that means the load given to conveyor becomes increases so that the

speed of motor gets reduced, which can be identified using this control window.

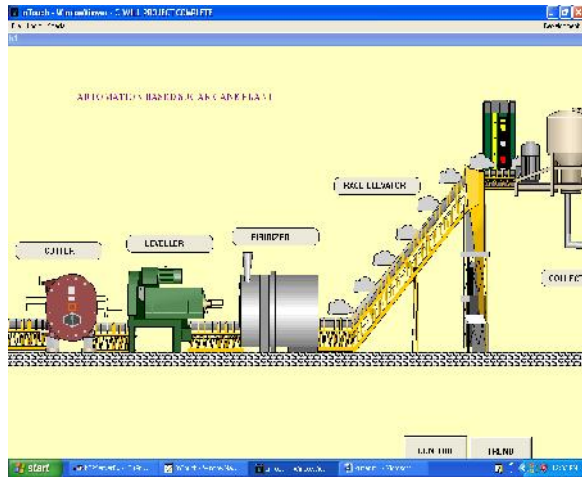

Fig. 4: - Simulation Automation based Sugar cane plant

Simulation of Automation based Sugar cane plant is as shown in figure 4. This is the process window.

SCADA is (INTOUCH) the quickest and easiest way to create Human Machine Interface (HMI) application for the Microsoft Windows 95, Windows NT operating system.

The sugar plant contains various stages involved in the production of sugar starting from the inflow of sugarcane into the crushing machine. The components are used in the mills are Cutter, Leveler, Fibirizer, Race elevator, Collector and Crusher. The detailed explanation about the components is given as follows:

a) Cutter:

The sugarcane who use to cut from the land and bundled them. As per the capacity of the cane cutter machine the bundle of sugarcanes are fedded into the cutter. It cuts the sugarcane from large size to small pieces. The cutted pieces are given to the leveler.

b) Leveler:

The cutted pieces of sugarcane are fedded into the leveler. Leveler levels the sugar cane entering in crusher with the help of Blades.

c) Fibrizer:

Fibrizers are used for shredding of sugarcane into fibres and open cells to enable prepared cane to crushed in between the rollers of the mills to extract juice are given through the race elevator.

d) Race Elevator:

Race elevators are used transporting the sugarcane. The prepared sugarcane are transferred from the bottom to the top direction.

e) Collector:

The waste and dust particles of sugarcanes are collected into the collector and the cutted cane is move to crushing machines.

f) Crusher:

The sugarcane is fedded into the crusher machine to extract juice.

IV. VARIABLE FREQUENCY DRIVE (VFD)

Electronic VFD’s rectifies the 50 Hz current and make a smooth DC voltage in capacitors (working like small batteries). In other words the frequency is “eliminated” from the system, or changed to zero. Then the VFD must create its own frequency by alternating the DC – voltage through transistors at the desired frequency. Also (very important) the voltage must be proportional to the frequency. You cannot output all 230 volts when the motor is near zero speed. The voltage is usually controlled by the amplitude of the sine output. Another way is to control the voltage at the input (rectifier) side.

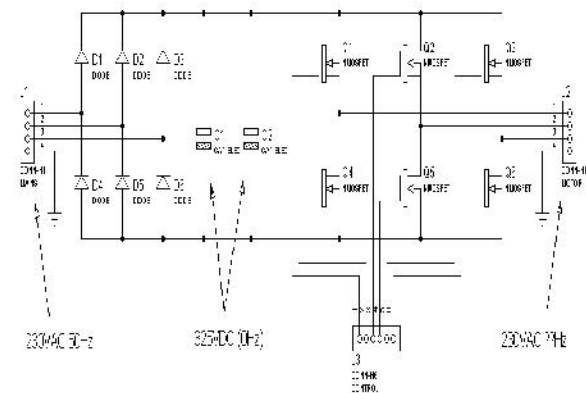

Fig. 5: - VFD Circuit Diagram

The fig.5 shows the power parts of a VFD. There are two “bridges” in the circuit, one three phase rectifier and one three phase inverter bridge. The rectifier (left) is working without any additional electronics. All electrical current is simply conducted in the same direction as the arrows in the diode symbols.

V. PROGRAMMABLE LOGIC CONTROLLER (PLC)

A Delta PLC is integrated kit. It Works at 230V AC and 24V DC and Capacity 15872 steps. The processor unit houses the microprocessor, memory and communications circuitry necessary for the processor to operate and communicate with the I/O and other peripheral equipment. The DC power required for the processor is provided either by a power supply that is an integral part of the processor unit or by a separate power supply unit.

Processors control as few as 8 or as many as 40,000 real word inputs outputs. The larger the number of input and output devices that are required for the process, the more powerful the processor must be to properly control the number of I/O that will be connected. The processor may be a self contain unit or may be molded in design.

VI. SUPERVISORY CONTROL AND DATA ACQUISITION SYSTEM (SCADA)

In Intouch applications span the globe in a multi tube of vertical markets including food processing, semi-conductors, oil and gas, automotive, chemical, and pharmaceutical, pulp and paper, transportation, utilities, and more.

By using Intouch, you can create powerful, full future applications that exploit the key features of Microsoft windows, including active X controls; ole, graphics, networking and more. Intouch can also we extended by adding custom active X controls, wizards, generic objects, and creating Intouch quick script extensions. In this project we are using INTOUCH WANDERWARE 9.5 SCADA Software.

All the intouch quick scripts are event driven. The event may be a data change, condition, mouse click, timer, and so on. The order of processing is application specific. The following briefly describes the types of scripts that you can create:

Script Type	Description
Application	Linked to the entire application
Window	Linked to a specific window

VII. RESULT

Motor Frequency Rating - When limit 1 is on then the graph shows frequency rating at 10 HZ. When limit 2 is on then the graph shows frequency rating at 30Hz and when limit 3 is on then the motor run at 50 Hz frequency as shown in fig .6.

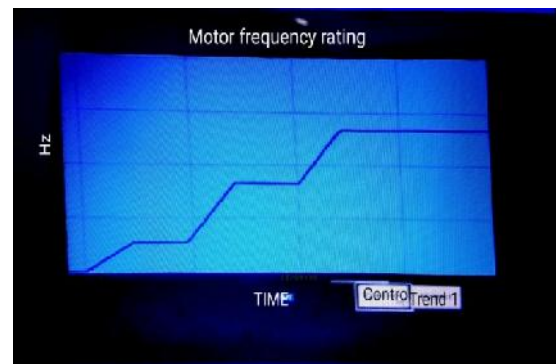

Fig. 6: - Motor Frequency Rating

Motor RPM Rating - The trend for motor RPM rating shown in fig.7. In the sugar factory there is number of motors will be run but here we are showing the result of only three motors? Let us taken as according to the limit taken in the motor frequency rating.

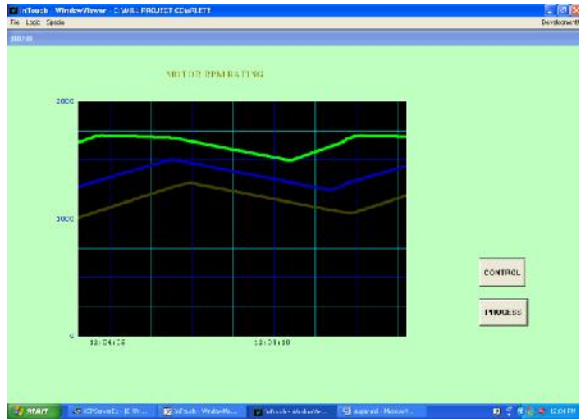

Fig. 7: - Motor RPM rating

VIII. CONCLUSION

The present work was motivated to develop a scheme and PLC is used to monitor and control a Variable Frequency Drive. A thorough study of all the hardware machinery was done including their functioning, specification and overall performance. The drive used in this setup offered different control modes of motor operation.

A complete study and useful hands on the PLC & the drive process have imparted a fairly good idea about the industrial automation system.

REFERENCES

- [1] N. Sadeesh1, P. Hema2, E. Prasannakumar3, S. Leelakrishnan4, "Automation of VFD Based Sugarcane Crusher with PLC and SCADA Control" International Journal for Research in Applied Science & Engineering Technology (IJRASET), Volume 4 Issue V, May 2016.
- [2] Peng Sun, Bin Ge, Xuan Zou, "Constant Pressure Water Supply System Control Using PLC" International Journal of Automation And Power Engineering, pages 73-76, published online www.ijape.org May 2012.
- [3] K GowriShankar, "Control of boiler operation using PLC-SCADA" International Multi Conference of Engineers and Computer Scientists, Vol. 2, ISBN: 978-988-17012-1-3, pages 19-21 March 2008.
- [4] S. Da'na, "Development of a monitoring and control platform for PLC-based applications" Journal Computer Standards & Interfaces, Vol. 30, No. 3, pages 157-166, March 2008.
- [5] Maria G. Ioannides, "Design and implementation of PLC-based monitoring control system for induction motor" IEEE Transactions on Energy Conversion, Vol. 19, No.3, pages 469-476, September 2004.
- [6] William J Weber, Robert M Cuzner, Eric Ruckstadter, Jim Smith, "Engineering fundamentals of multi-MW Variable Frequency Drives" Proceedings of the thirty-first Turbo machinery Symposium, pages 177-194, 2002.