

Design and Development of Raisins Drying Machine

SHAMUVEL V. PANDIT¹, JITENDRA G. SHINDE², SUNIL J. KADAM³

^{1, 2, 3} Dept. of Mechanical Engineering, Bharati Vidyapeeth's College of Engg., India

Abstract -- Raisin is popular dry fruit item with long life around 6 months if stored properly. Apart from use as a dry fruit item, it is used in large quantities in many sweet preparations, some bakery product items and desserts. Raisins are also used in some herbal medicine preparation. Harvesting of grapes start from January and ends by may every year. Hence this business is seasonal and factories work for 6 months every year. So to reduce that high percentage of moisture they carry conventional process for reducing this moisture as per requirement but this process takes more time, man power as well as money. It requires sun rays which is dependent on time and season as well as it changes with day time. In rainy season it is very difficult to dry the raisin because of lack of sun rays and procedure adopted for this very sophisticated. Above problem was explained by ordinary farmer we have taken opinion from them and find out that we have developed such machine. The detail development of raisin drying machine is presented in this paper.

I. INTRODUCTION

Raisins are basically dry grapes and are known as Kishmish, bedana, manuka or dry fruits. Sangali and Nashik districts grow large quantities of grapes and many growers or gardeners are keen to supply to raisin makers due to assured market. Maharashtra is therefore preferred location. Raisin is popular dry fruit item with long life around 6 months if stored properly. Apart from use as a dry fruit item, it is used in large quantities in many sweet preparations, some bakery product items and desserts. Raisins are also used in some herbal medicine preparation. Harvesting of grapes start from January and ends by may every year. Hence this business is seasonal and factories work for 6 months every year.

The outer layers and surface of raisin berries have physical and chemical mechanisms to resist water loss and nature's way of keeping the berry hydrated and turgid. The principal barrier is the raisins cuticle, which includes the outer layer of wax or bloom. This wax consists of partially overlapping flat platelets

that are irregular or lacelike in texture. Their orderly spacing and arrangement and the chemical characteristics of the wax provide water repellence and vapor loss resistance. During drying, water in the grape berry moves in the liquid phase through the cells to the cuticle. It must then pass as vapor through the wax platelets and evaporate from the outside surface. Water movement within the grape is speedy in comparison to the slow transfer of water through the cuticle. The rate of water loss from the berry is dependent on the water's rate of transfer and availability at the berry surface. The transfer rate is governed by differences between the vapor pressure of the fruit and that of the surrounding air, referred to as vapor pressure deficit or evaporative potential. Vapor pressure deficits are greatest with a high berry temperature and a low relative humidity. High air temperatures and rapid air movement contribute to low relative humidities of these factors; berry temperature is the most important driving force in field drying.

1. Most of agricultural product content moisture. This is directly affected on product make in farm.
2. In raisin production process dry raisins are washed for cleaning purpose.
3. After washing process surface moisture of raisins get increased.
4. So to reduce that high percentage of surface moisture they carry conventional process for reducing this moisture as per requirement but this process takes more time, man power as well as money. It requires sun rays which is dependent on time and season as well as it changes with day time.
5. In rain season it is very difficult to reduce moisture because of lack of sun rays. And procedure adopted for this very sophisticated.

6. Above problem was explained by ordinary farmer we have taken opinion from them and find out that we can develop such machine.
7. Hence we experienced that it need to develop machine which overcomes above problems economically.

II. COMPONENTS OF RAISIN DRYING MACHINE

Components used for manufacturing of machine given below in table 1.

Sr. No.	Part Name	Material	Quantity
1	Motor ½ hp	Standard	1
2	Worm Gear box	MS	1
3	Fixed sheet metal box	GI	1
4	Conveyor Belt	Rubber	1
5	Idler Pulley	MS	7
6	Bearing	White Metal	14
7	Coupler	MS	1
8	Bolt	MS	10
9	Screws	Alloy	60
10	Foundation	MS	1
11	Pulley	MS	2
12	Belt	Polymer	1
13	Heating coil	Nichrome	4
14	Digital Moisture Meter	Standard	1

Table no.1: Part List

III. WORKING OF MACHINE

Fig. 1 shows assembly of raisin dryer. The motor is rotated in clockwise direction and gearbox output shaft is rotated in anticlockwise direction. When electric supply is start the motor is turn on. The motor is coupled with gear box with the help of coupling; hence output shaft of gear box is rotated. The output shaft of the gear box is connected to the shaft with help of belt pulley arrangement attached to them. Due to belt pulley arrangement required constant speed is achieved so that conveyor rotates as per requirement. The motor and gear box arrangement is based on

main foundation of machine which is below the conveyor.

The raisins are feed on the conveyor belt at one end of machine as per our need. The continuous supply of raisins is provided on conveyor belt by using manually controlling arrangement.

There are four heating coils are provided inside the rotating drum. These four heating coils fixed with casing with help of attachment and fitted by nut and bolt and clamping strip. Thus heating element is hanging in air and continuously radiate heat and makes air heated which is exact we want to heat atmosphere inside casing. In casing we have provided fan arrangement at top above the heater such way that heated air inside casing should be uniformly distributed and resulted into directional moisture reduction in raisins.

Whole arrangement of conveyor as well as fixed casing and heating arrangement also mounted on rigid channel along with supports. Seven idler pullies are connected between two channels. These pullies supports the conveyor belt. All assembly mounted that should withstand that load without any vibration is whole machine.

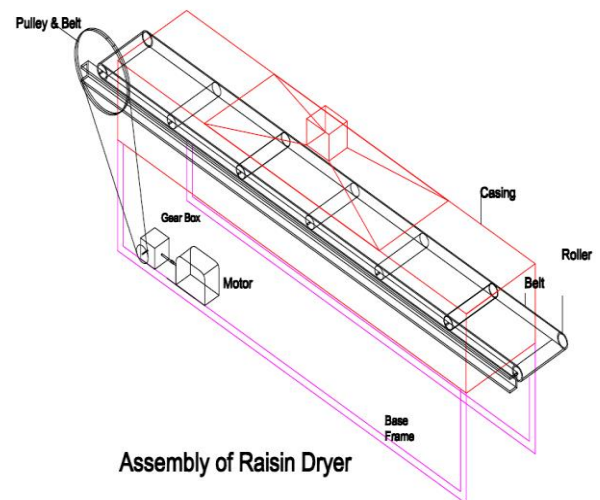

Assembly of Raisin Dryer

Fig. 1 Assembly of Raisin Dryer

Heat generation-During working, temperature in casing increases up to the 50 to 55 degree Celsius. This temperature is not harmful to raisins. While passing through casing surface moisture is removed.

Surface of raisins is totally dry after passing through machine but raisin become little soft because of sugar content.

We have created 2-D model of raisin dryer in AUTO-CAD 2009 software. The Orthographic view are shown in fig. no.2

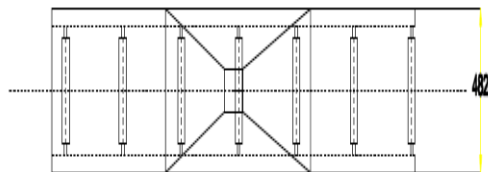
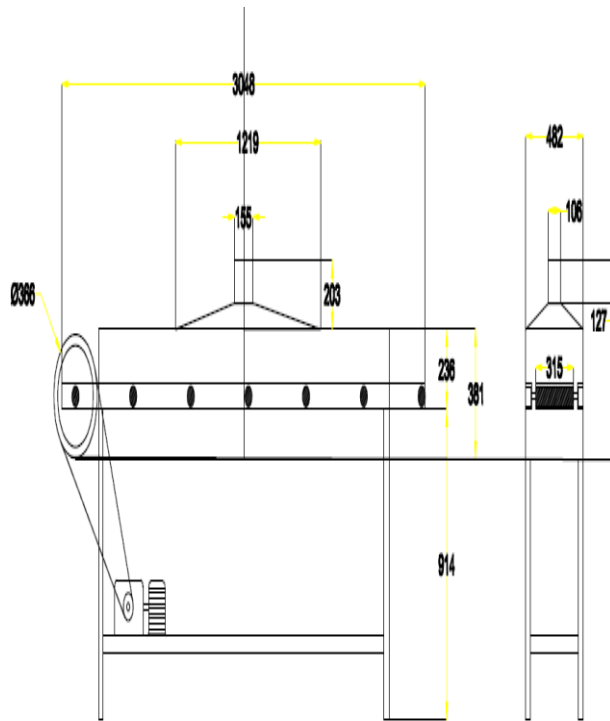

Fig. 2: 2-D design of Raisins Drying Machine

IV. DESIGN CALCULATION

Pitch diameter of gear wheel = 60 mm, Pitch diameter of worm gear = 32mm, Number of starts on the worm :-($z_1=1$)

Number of teeth on worm wheel: - ($z_2=29 \times 4$)

Permissible torque on worm wheel (i)

$$i = \frac{z_2}{z_1} = \frac{116}{1} = 116$$

Motor speed (N_1) = 1440,

$$\text{Output speed of gear box } (N_2) = \frac{N_1}{i} = \frac{1440}{116} = 14 \text{ rpm}$$

• Selection of Electric Motor:

• Motor Power Required for the Machine:-

Power requirement mainly depends upon torque required at required speed. First we calculate torque required to drive net drum. Therefore,

$T = I \times a$ Wher I = moment of inertia, a = acceleration

$$I = m \times R^2$$

Where, M = mass of belt + mass of raisins present on the belt = 44 kg

R = radius of net drum = 0.1828 m. Therefore

$$I = 44 \times 0.1828^2 = 1.4602 \text{ kg.m}^2$$

$$A = R\omega^2$$

$N = 10 \text{ rpm}$

$$\omega = \frac{2\pi n}{60} = 1.047 \text{ rad/sec}$$

$$A = 1.047^2 \times 0.1828 = 0.2005 \text{ m/sec}^2$$

Now torque

$$T = 1.047 \times 0.2005 = 0.2099 \text{ Nm}$$

Now calculating power required

$$P = \frac{2\pi nT}{60} = 0.2198 \text{ Kw} = 219.8/746 = 0.2946 \text{ HP.}$$

Here we choose 0.5 HP motor.

• Specifications:-

- 1] Power: - 0.5 H.P.
- 2] RPM: - 1440 (single speed)
- 3] Phase: - Single
- 4] Voltage: - 230 V / 240V
- 5] Current: - Ampere
- 6] Warranty period: - 1 year
- 7] Frequency: - 50 HZ.
- 8] Motor location: - Mounted on motor bracket situated at the MIC Frame.
- 9] Drive: - Gear drive
- 10] Site condition:-
 - a) Maximum ambient Temp = 40°C

- b) Humidity = Maximum 75%
- c) Area of operation = Non hazardous
- b) Design of Pulley:

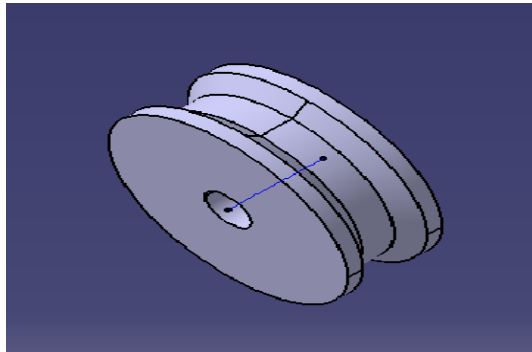

Fig.3 CAD of Large Pulley

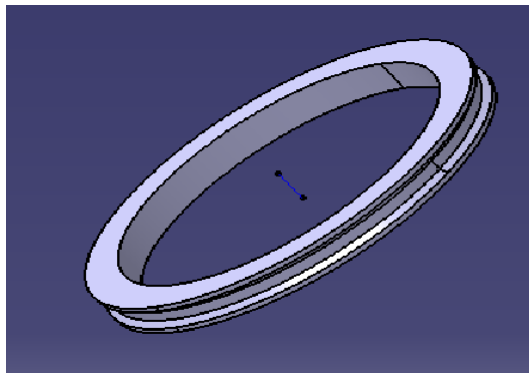

Fig. 4 CAD of Small Pulley

The CAD model of large pulley and small pulley is shown in Fig. 3 and Fig. no.4 respectively.

$$N1 = 14 \text{ rpm}, D1 = 55\text{mm}, D2 = 350\text{mm}, N2 = ?$$

$$\frac{N1}{N2} = \frac{D2 + t}{D1 + t}$$

$$\frac{14}{N2} = \frac{360}{60}$$

$$N2 = 9.7\text{rpm} = 10\text{rpm}$$

V. RESULT AND DISCUSSION

Comparison of Manual and Machine Process for drying of one ton of raisins according to manpower, time and cost.

When we are using moisture reducing machine for drying of raisins,

- 1) Weather condition does not affect on process of drying.
- 2) Machine takes less time to dry raisins up to 15 to 20 mints as moisture present in raisins.
- 3) It required less space.
- 4) Cost behind drying process is very less as compare to conventional process of solar ray drying.

Following chart shows the cost and man power required by drying machine is use in single pass through machine.

No.	Work done	Manpower required	Cost (Rs.)
1	Feeding raisins in machine	1	250
2	Collecting raisins in machine	1	250
2	Heating and belt running cost per ton	0	250
3	Machine maintenance	1	150

Table 2: Cost as Per Machine Process

For each pass % of moisture is reduced by 5. Hence, to reduce % of moisture by 10 we need pass the raisins 2 times in machine.

Total cost of drying for 1 ton is 900 Rs with 3 man powers by using machine in only 1 days.

So as per above calculations total profit by using machine is 1100 Rs per ton.

Now we have calculated that when total machine cost will nil.

We know that,

For 1 ton of raisins profit is 1100 Rs.

And cost of machine is 30000 Rs.

When profit reaches above 30000/- Rs, then machine cost gets nil.

So for how much of kg of raisins required to pass through the machine that profit will be 30000 Rs

So, calculating how much kg of raisins required to pass through the machine to overcome the profit equal to 30000 Rs.

$$\text{Quantity in kilograms} = \frac{1 \times 30000}{1100} = 27 \text{ Tonns}$$

So to nil 30000 Rs cost of machine we required to pass 27 tons of raisins through machine.

Comparison of Manual and Machine Process for drying of one ton of raisins according to manpower, time and cost.

COMPARISON	MANUAL	MACHINE
Man Power	8	3
Time	2 days	1 days
Cost	2000	900

Table 3: Comparison of Manual and Machine Process

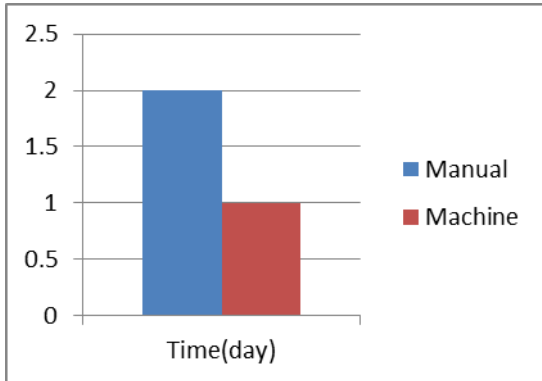

Fig. 5. Comparison of Manual and Machine Process graphically

- Advantages of Machine:
 - 1) The machine is compact in size and simple in operation.
 - 2) Less time required for operation
 - 3) As compared to other machines this machine is cheaper in cost.
 - 4) Flow of raisins is easily adjusted by manually.
 - 5) Special modifications can be made in the machine as per the requirement.
 - 6) Simple in construction and less no. of parts.
 - 7) Unskilled worker can operate the machine easily.

VI. CONCLUSION

In this way our raisin drying machine is effective and simple from ease of operation for reducing moisture at any time any season with less time, manpower and money. It is also affordable to all farmers. Unskilled worker can operate the machine easily. It substitutes for conventional process of grain drying. Hence it is reliable system. Our raisin drying machine not only used for drying of raisin but it is also used for drying of cashew nuts, ground nuts, sunflowers, various beans which need to dry etc. We have reduced moisture of raisin from 13% to 15%. Raisin drying machine can use for drying of medical products such as drying of medical pills.

REFERENCES

- [1] Sangali Grapes Processing, Marketing and reaserch Limited, Gat. no.1952, Subhash nagar, Tal. Miraj, Dist. Sangali, Maharashtra.
- [2] Aguilera, J. M., K. Oppermann, and F Sanchez. 1987. Kinetics. of browning of ‘Sultana’ grapes. Jour. Food Sci. 52:991– 93.
- [3] Christensen, L. P., W. M. Miller, M. L. Bianchi, and M. M.Moriyama. 1992. Raisin sugaring studies: Effects of variety, fruit maturity, cultural practices, and drying temperatures on raisin sugaring. In Raisin Research Reports, 1992. Fresno: California Raisin Advisory Board. 169–80.
- [4] Clary, C. D., and V. E. Petrucci. 1982. Effect of light, temperature, and spraying regime on the color and quality of amber (SOT) seedless raisins, final report. In Raisin research reports, 1982. Fresno: California Raisin Advisory Board. 263–92.
- [5] Miller, W. M., and C. O. Chichester. 1960. The constituents of the crystalline deposits of dried fruit. Food Res. 25:3,424–28.
- [6] Enochian, R. V., M. D. Zehner, S. S. Johnson, and V. E. Petrucci. 1976. Production costs and consumer acceptance of dried-on-the-vine raisins. Fresno: USDA Econ. Res. Serv.Agric. Econ. Rpt. No. 337.
- [7] Whiting, J. R. 1992. Harvesting and drying of grapes. In B. G.Coombe and P. R. Dry, eds., Viticulture, Vol. 2: Practices. Adelaide, Australia: Wine titles.

- [8] Singleton, V. L., E. Trousdale, and J. Zaya. 1985. One reason sun-dried raisins brown so much. *Am. J. Enol. Vitic.*36:111–13.
- [9] Alden M, P.Torkington and Strutt A.C.R (1988) “Control and Instrumentation of a Fluidized Bed Dryer using Temperature.
- [10] Differences Technique”, Development of a working Model power Technology. Ambrosio-Ugri M.C.B and Taranto O.P, (2006)