

Motion Controlled Wireless Robot Arms to Use in Medical Sector

R.M.S.B RATNAYAKE

Abstract- The modern world has been moving towards inventions of technology that help mankind with the ease of operations. The main focus of these development revolves around the concerns of aiding, accessing and operating in conditions that are naturally not available. Construction of artificial arms have been a growing technology in the past decades that has become a pinnacle of the cutting-edge technology in major fields such as Medicine, Military, Automobile and many other manufacturing facilities. With these growing requirements for the technology, the demand for the operation professionals such as Doctors for example have become highly competitive for medical attentions around globe in many specialist fields and are mostly travelling around from destination to destination which compromises their availability for a specific location. In the systems currently existing, controllers utilized are built around the constraint of having freedom of operation within the vicinity range and hence an ideal wireless system that the operator can use remotely is a design idea that the system of Robotic arms can utilize as the next advancement in the field.

Indexed Terms- Microcontroller, Robot Arm.

I. INTRODUCTION

Robotic Arm assisting mechanisms have become a common part of many day-to-day operations in the fields of the modern era. Systems such as Assembly units, Repair bays, and Basic projects mostly include a robotic arm which can simulate similar outcomes to that of a human arm. The arms are highly capable of carrying more weights, touch toxic or corrosion materials given that the arm is made of anti-corrosion/toxic materials etc, in general sense can perform actions that of which a normal physical operation by humans are non-viable.

Robotic arm technologies compromise of using varies mechanical approach such as;

1. Electromechanical
2. Hydraulic and Pneumatic – Fluid controlled

Most applications in the current era that utilizes robotic arms are being fully automated and hence the concept of controllers have been minimized but still applications such as aforementioned Da Vinci Machine, where the doctor's input is very important, the controller designs are still a valiant subject in the field of engineering of these systems.

The idea behind the project is based on the limitations of systems similar to Da Vinci and other robotic control applications being severely limited in range. This calls for professionals to travel across the globe to fulfill demands such as surgeries and other technological based solutions consumes great deal of time and energy.

The system designs under prior art searches show that controller designs of much system do not have freedom of operation for the user while being limited to fixed linear motion such as knobs or linear axles. This causes distress in operation and creating inaccuracy to a point where the complete system is neglected.

This unavailability of professionals and neglect of the system disturbs the smooth operations of many sectors such as health, manufacturing, economics etc., which faces decline in growth for which the intended systems can greatly help in achieving.

A system is designed with the considerations of freedom of operations such as movement or gestures that can help control robotic arms which can be operated through a channel that is free of any physical restraints. This calls for a wireless communication network under the movement mechanics where

multiple systems are to be designed to help check and overcome the restraints of the existing systems.

The proposed design consists of a glove that can replicate the motion of the hand, A wireless platform to transmit the motion signal and a robotic arm to replicate the motion of the glove.

II. TESTING CONFIGURATION

With the guidelines obtained from the research and prior art searches, it is visible that many systems chose accelerometers in combination with the AVR microcontroller kit as the preferred choice. The design element seems viable in creating a prototype system which can also utilizes the same aspect. The system proposal for the problem solution will be to create accelerometer-based controller glove that can obtain values from the 3 axis X, Y and Z while transmitting them wirelessly across a channel to a centralized system or the Electromechanical Robotic arm directly. It seems ideal to create the robotic arm along with the centralized server. The major focus of the project will rely on the controlling the robotic arm using wireless communication platform.

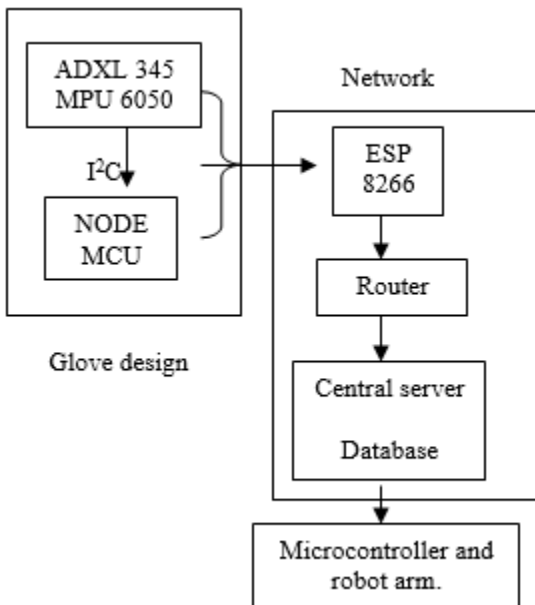

Fig 1.1 System Block Diagram

III. TEST RESULTS

Outputs of pitch and roll from the accelerometer and bent unbent signals from flex sensor of the glove is shown below.

```

COM11
FlexSense = 155
mappedRawX = 76
mappedRawY = 94
FlexSense = 155
mappedRawX = 76
mappedRawY = 92
FlexSense = 155
mappedRawX = 75
mappedRawY = 94
FlexSense = 155
mappedRawX = 76
mappedRawY = 93
FlexSense = 155
mappedRawX = 75
mappedRawY = 93
FlexSense = 155
mappedRawX = 75
mappedRawY = 93
FlexSense = 155
mappedRawX = 76
mappedRawY = 92
FlexSense = 155
mappedRawX = 75
mappedRawY = 93
FlexSense = 155
  
```

Fig 1.2 Pitch Down

```

COM11
-----
flexsense = 75
mappedRawX = 138
mappedRawY = 103
FlexSense = 75
mappedRawX = 137
mappedRawY = 104
FlexSense = 75
mappedRawX = 137
mappedRawY = 103
FlexSense = 75
mappedRawX = 137
mappedRawY = 103
FlexSense = 75
mappedRawX = 138
mappedRawY = 103
FlexSense = 75
mappedRawX = 138
mappedRawY = 103
FlexSense = 75
mappedRawX = 137
mappedRawY = 103
FlexSense = 75
mappedRawX = 137
mappedRawY = 103
FlexSense = 75
mappedRawX = 138
mappedRawY = 103
FlexSense = 75

```

Autoscroll Show timestamp

Fig 1.3 Pitch Up

```

COM11
-----
flexsense = 155
mappedRawX = 118
mappedRawY = 25
FlexSense = 155
mappedRawX = 106
mappedRawY = 67
FlexSense = 155
mappedRawX = 96
mappedRawY = 103
FlexSense = 155
mappedRawX = 108
mappedRawY = 64
FlexSense = 155
mappedRawX = 121
mappedRawY = 25
FlexSense = 155
mappedRawX = 113
mappedRawY = 31
FlexSense = 155
mappedRawX = 112
mappedRawY = 35
FlexSense = 155
mappedRawX = 115
mappedRawY = 25
FlexSense = 155

```

Autoscroll Show timestamp

Fig 1.5 Roll Right

```

COM11
-----
flexsense = 155
mappedRawX = 106
mappedRawY = 153
FlexSense = 155
mappedRawX = 106
mappedRawY = 153
FlexSense = 155
mappedRawX = 107
mappedRawY = 152
FlexSense = 155
mappedRawX = 106
mappedRawY = 153
FlexSense = 155
mappedRawX = 105
mappedRawY = 154
FlexSense = 155
mappedRawX = 105
mappedRawY = 153
FlexSense = 155
mappedRawX = 105
mappedRawY = 152
FlexSense = 155
mappedRawX = 106
mappedRawY = 153
FlexSense = 155

```

Autoscroll Show timestamp

Fig 1.4 Roll left

```

COM11
-----
FlexSense = 155
mappedRawX = 108
mappedRawY = 116
FlexSense = 155
mappedRawX = 107
mappedRawY = 113
FlexSense = 155
mappedRawX = 110
mappedRawY = 115
FlexSense = 155
mappedRawX = 109
mappedRawY = 117
FlexSense = 155
mappedRawX = 109
mappedRawY = 116
FlexSense = 155
mappedRawX = 109
mappedRawY = 114
FlexSense = 155
mappedRawX = 109
mappedRawY = 114
FlexSense = 155
mappedRawX = 110
mappedRawY = 113
FlexSense = 155
-----
 Autoscroll  Show timestamp
    
```

Fig 1.6 Flex sensor Unbent.

```

COM11
-----
FlexSense = 75
mappedRawX = 113
mappedRawY = 109
FlexSense = 75
mappedRawX = 113
mappedRawY = 110
FlexSense = 75
mappedRawX = 113
mappedRawY = 108
FlexSense = 75
mappedRawX = 106
mappedRawY = 106
FlexSense = 75
mappedRawX = 113
mappedRawY = 108
FlexSense = 75
mappedRawX = 113
mappedRawY = 109
FlexSense = 75
mappedRawX = 113
mappedRawY = 109
FlexSense = 75
mappedRawX = 112
mappedRawY = 109
FlexSense = 75
-----
 Autoscroll  Show timestamp
    
```

Fig 1.7 Flex sensor Unbent.

These results clearly show that the sensors and the accelerometer are successfully working and the radio frequency transmission is efficiently working without errors. The values are scaled to be within the range of no constraint for the servo motors hence the values are servo position values.

Following figure shows the reception of the packets through wireless network.

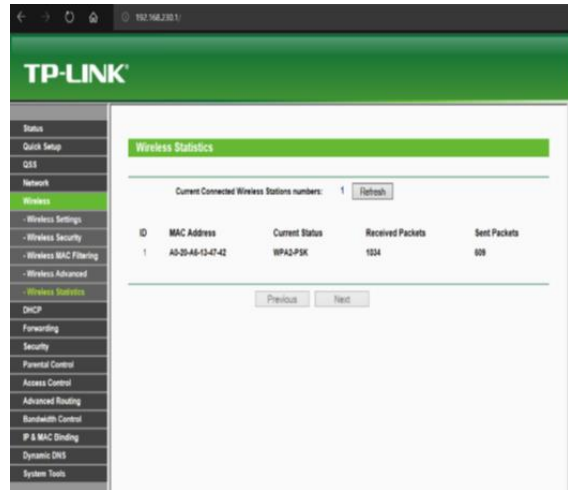

Fig 1.8 Confirming the Received data

Since the router has confirmed that the packets have been passed through successfully, the MySQL database checked if the exact values that been read are being injected there.

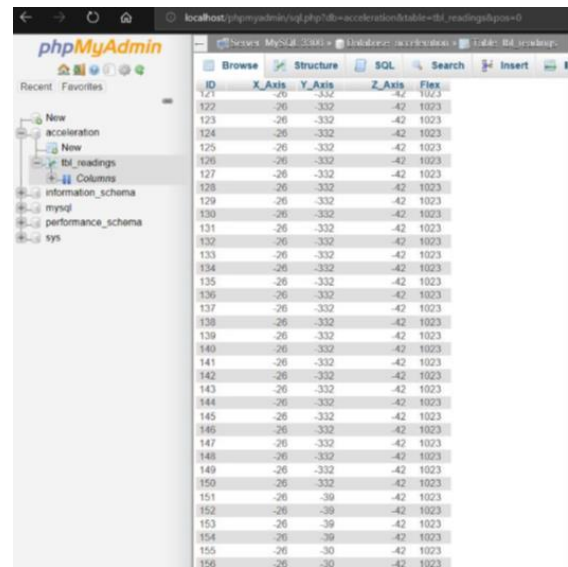

Fig 1.9 Confirming the Received data to database

This helps confirm that the data is being injected into the database directly and can easily be retrieved by the Robotic arm controller using the SELECT SQL query. This operation can also be done using Matlab where a infinite for loop can be implemented to read data as soon as the connection is established and serially write these data to a AVR Robotic arm system.

Scientific Engineering and Research (IJSER), pp. 324-329, 2012.

CONCLUSION

The Paper is a research and proof of concept development of a system that can utilize wireless communication channels to control a robotic arm. It was discussed on how the robotic arms movement can be obtained by using a motion-based input, in terms; an accelerometer to obtain the Cartesian plane values to move the robotic arm. A brief description on the path taken to building a prototype robotic arm that can be used within the realms of this paper. The design idea behind the project is solely in the purpose of checking the feasibility of the wireless communication system which many people only try to theorize. The innovative approach in trying to add the Wi-Fi based wireless communication model that can still achieve the mode of communication is quiet fascinating the growing world that a robotic arm can be controlled within 120ms from one end of the world to another and yet the 120ms is very slow compared to the standards expected.

REFERENCES

- [1] Zain Anwar Ali 1, M. Tanveer², Habib Shaukat 2 and Saad Anwar 3, "Android Operated Robotic Arm", *Universal Journal of Control and Automation*, vol. 2, no. 1, pp. 13, 2014.
- [2] NeerparajRai, palzorgyatsobhutia and uditpradhan, "Re mote learning: android operated educational robot arm with 6 dof", *Universal journal of control and automation*, vol. 2, no. 4, pp. 1-7, 2014.
- [3] Babul Salam Kader Ibrahim, "Robotic ARM controlling used internet", *International Symposium on Robotics and Intelligent Sensors (IRIS)*, pp. 364-370, 2012
- [4] Ritika Pahuja and Narender Kumar, "Android Mobile Phone Controlled Bluetooth Robot Using 8051 Microcontroller", *International Journal of*